

Axley

004331



SE KOLGRILL

Bruksanvisning i original
Viktigt! Läs bruksanvisningen noggrant innan användning!
Spara den för framtida behov.

NO KULLGRILL

Bruksanvisning
(Oversettelse av original bruksanvisning)
Viktig! Les bruksanvisningen nøye før bruk.
Ta vare på den for fremtidig bruk.

PL GRILL WĘGLOWY

Instrukcja obsługi
(Tłumaczenie oryginalnej instrukcji)
Ważny! Przed użyciem uważnie przeczytaj instrukcję obsługi!
Zachowaj ją na przyszłość.

EN CHARCOAL GRILL

Operating instructions
(Translation of the original instructions)
Important! Read the user instructions carefully before use.
Save them for future reference.

Värna om miljön!

Får inte slängas bland hushållssopor! Lämna produkten för återvinning på anvisad plats, till exempel kommunens återvinningsstation.

Rätten till ändringar förbehålles.

Vid eventuella problem, kontakta vår serviceavdelning på telefon 0200-88 55 88.

www.jula.se

Verne om miljøet!

Må ikke kastes sammen med husholdningsavfallet! Lever produkt till gjenvinning på anvist sted, f.eks. kommunens miljøstation.

Med forbehold om endringer.

Ved eventuelle problemer kan du kontakte vår serviceavdeling på telefon 67 90 01 34.

www.jula.no

Dbaj o środowisko!

Nie wyrzucaj zużytego produktu wraz z odpadami komunalnymi! Produkt należy oddać do odpowiedniego punktu składowania lub przynieść go do jednego ze sklepów gdzie przy zakupie nowego sprzętu bezpłatnie przyjmujemy stary tego samego rodzaju i w tej samej ilości.

Z zastrzeżeniem prawa do zmian.

W razie ewentualnych problemów skontaktuj się telefonicznie z naszym działem obsługi klienta pod numerem: 22 338 88 88.

www.jula.pl

Care for the environment!

Must not be discarded with household waste! Leave the product for recycling at the designated station e.g. the local authority's recycling station.

Jula reserves the right to make changes. In the event of problems, please contact our service department.

www.jula.com

Tillverkare/ Produsent/ Producenci/ Manufacturer

Jula AB, Box 363, 532 24 SKARA

Distributør/ Distributør/ Dystrybutor/ Distributor

Jula Poland Sp. z o.o., ul.

Malborska 49, 03-286 Warszawa, Polska

Jula Norge AS, Solheimsveien 6-8,

1471 LØRENSKOG

2018-07-04

© Jula AB

1

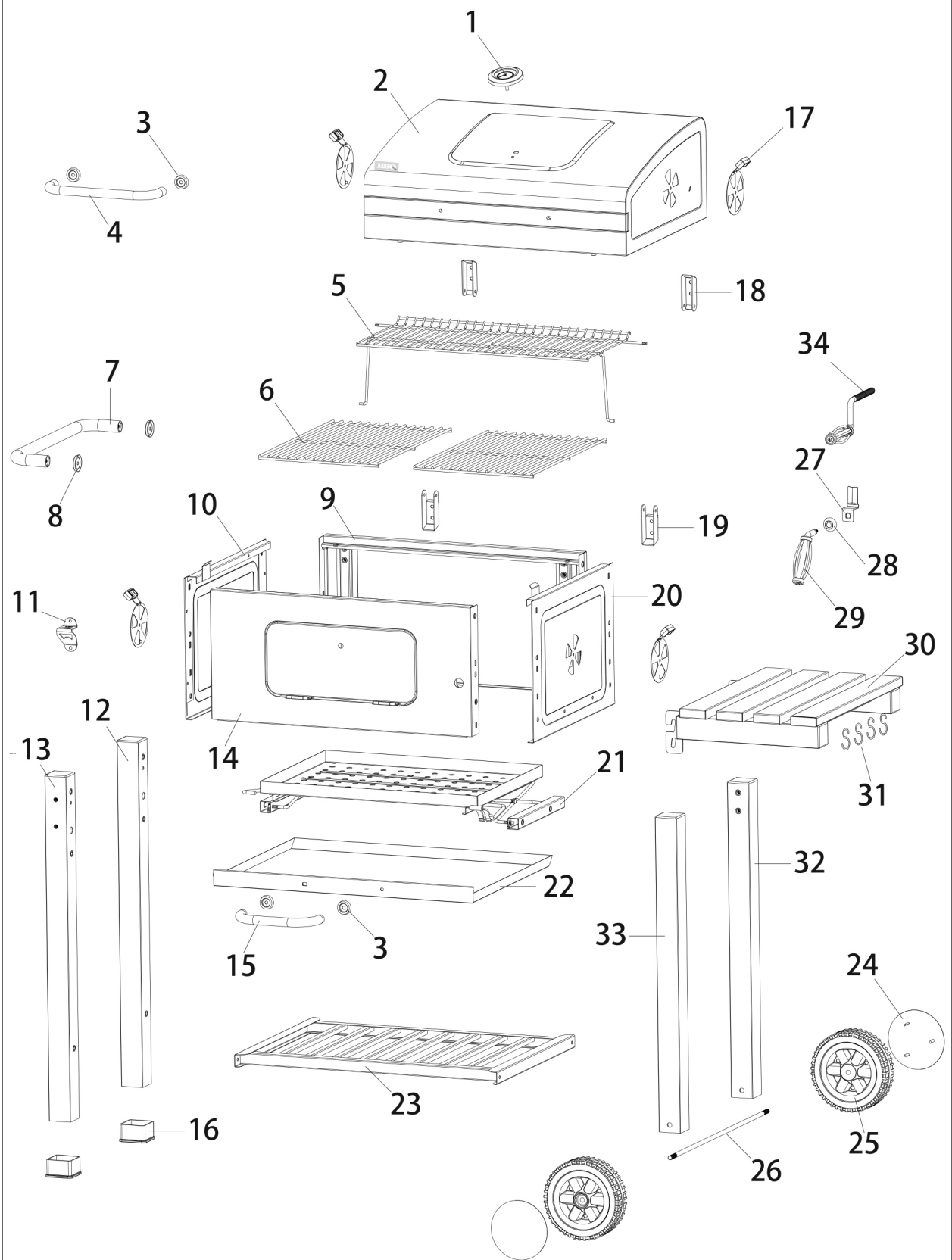

2

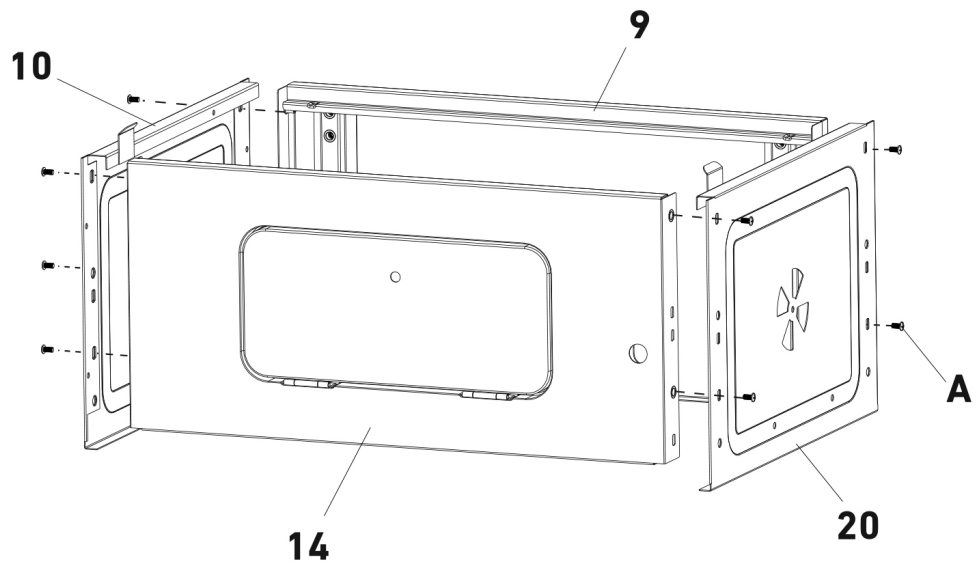



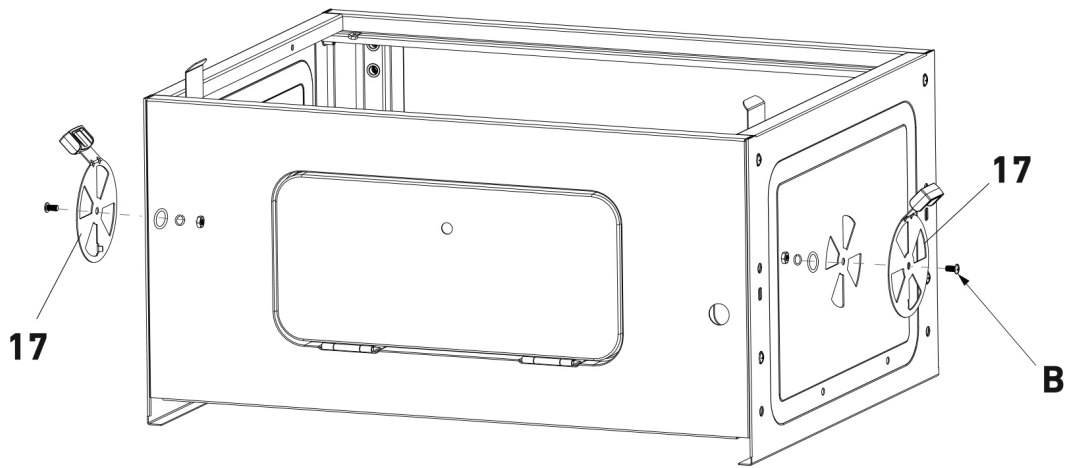

A		M6X12	x 8

3

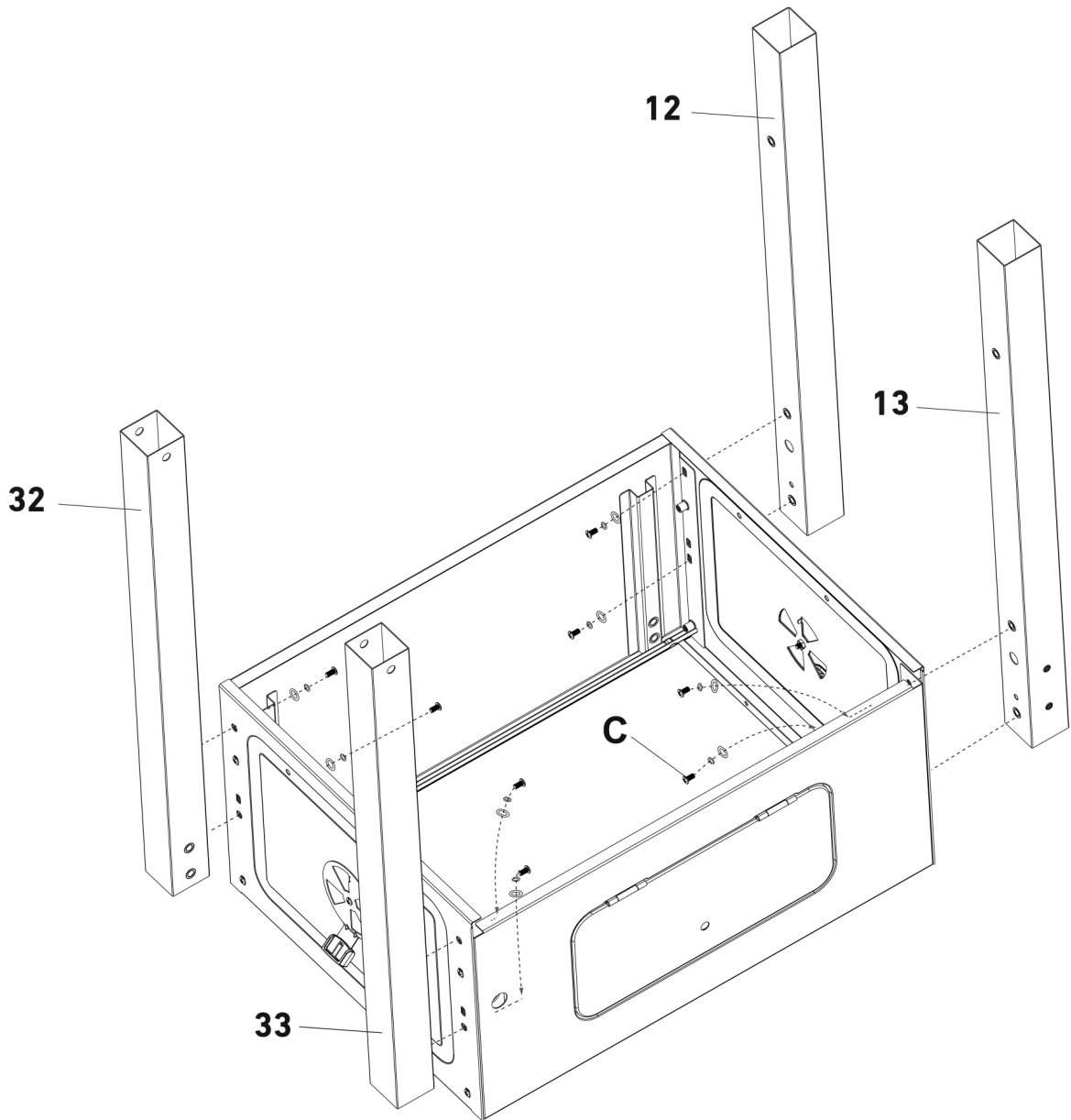

B		M6X12	x 2
		Ø6X16	x 2
		Ø6	x 2
		M6	x 2



C		M6X20	x 8
		Ø6X16	x 8
		Ø6	x 8

5

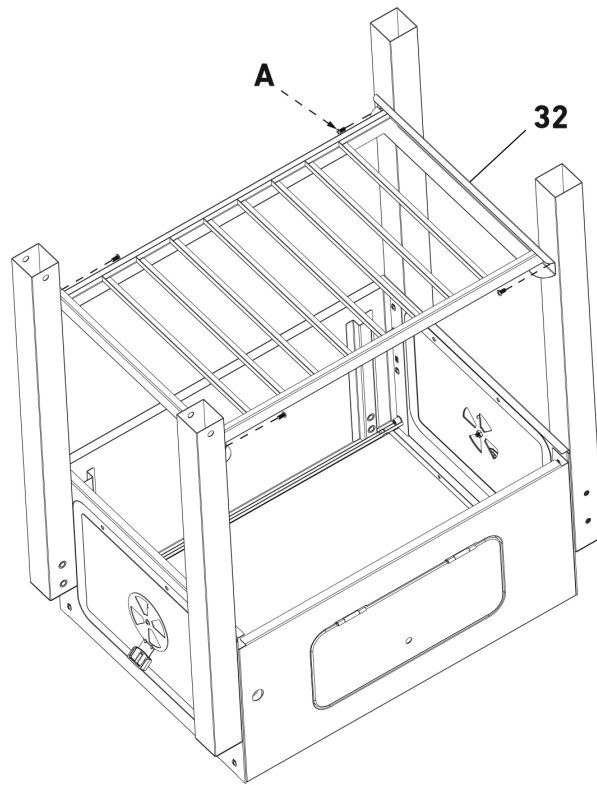





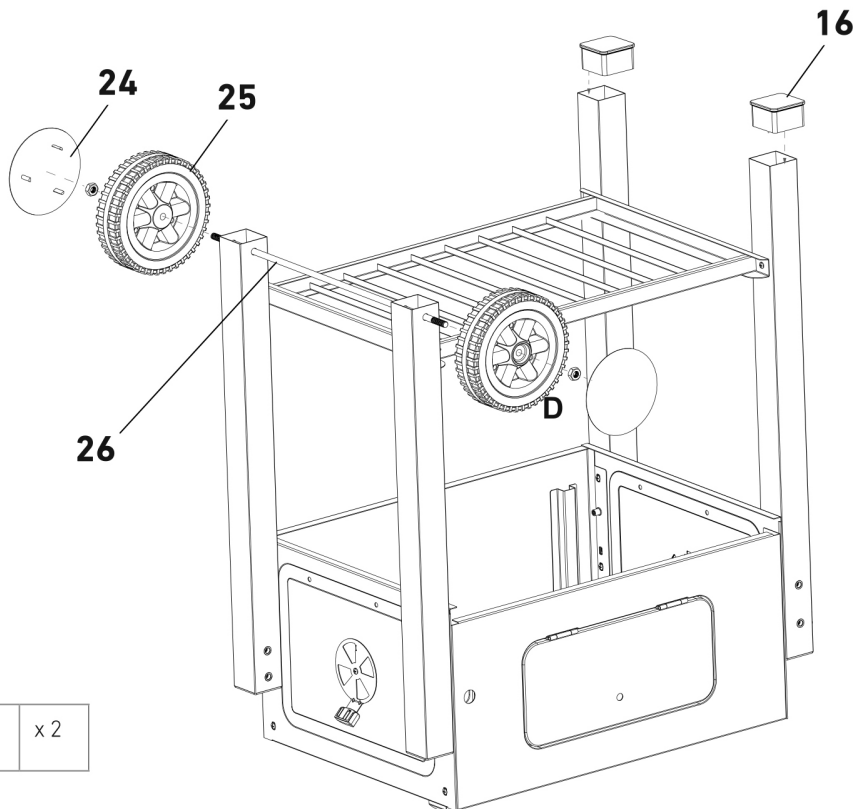

A			M6X12	x 4
----------	---	---	-------	-----

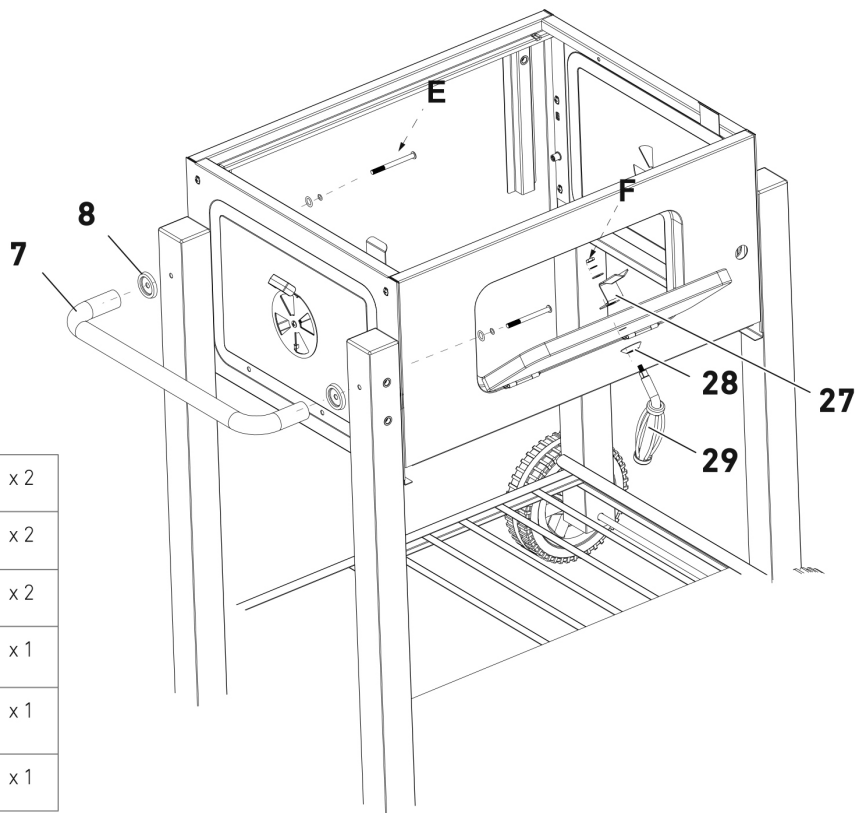
6



D			M10	x 2
----------	---	---	-----	-----

7

E		M6X80	x 2
		Ø6X16	x 2
		Ø6	x 2
F		M6	x 1
		Ø6X16	x 1
		Ø6	x 1

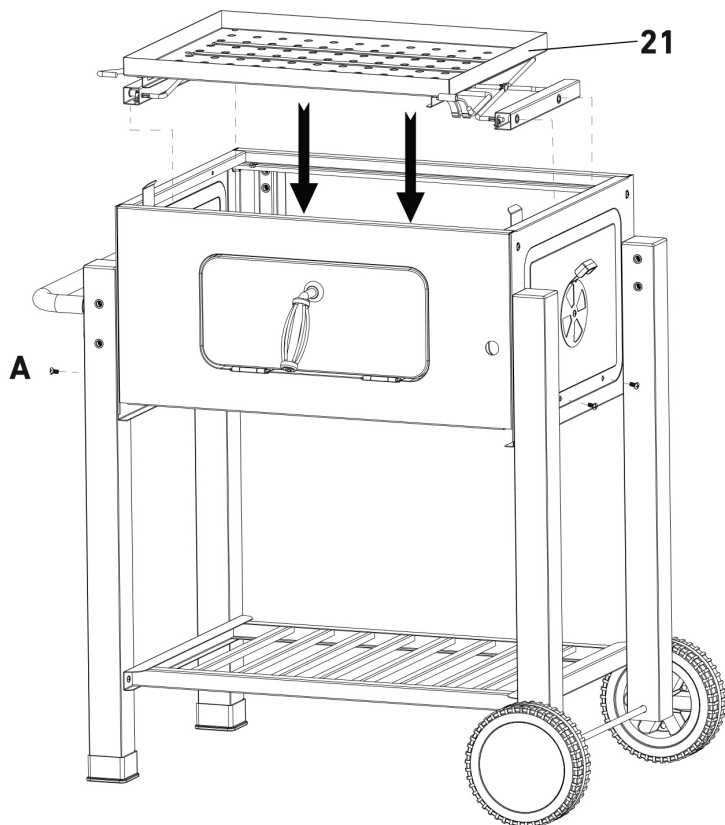
8

A		M6X12	x 4
----------	---	-------	-----

9

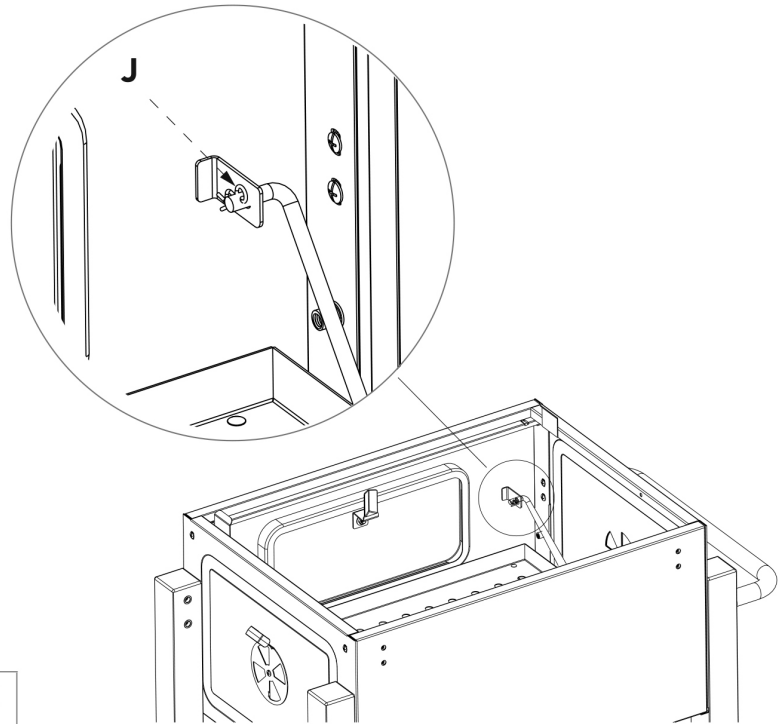

J			x 1
----------	--	--	-----



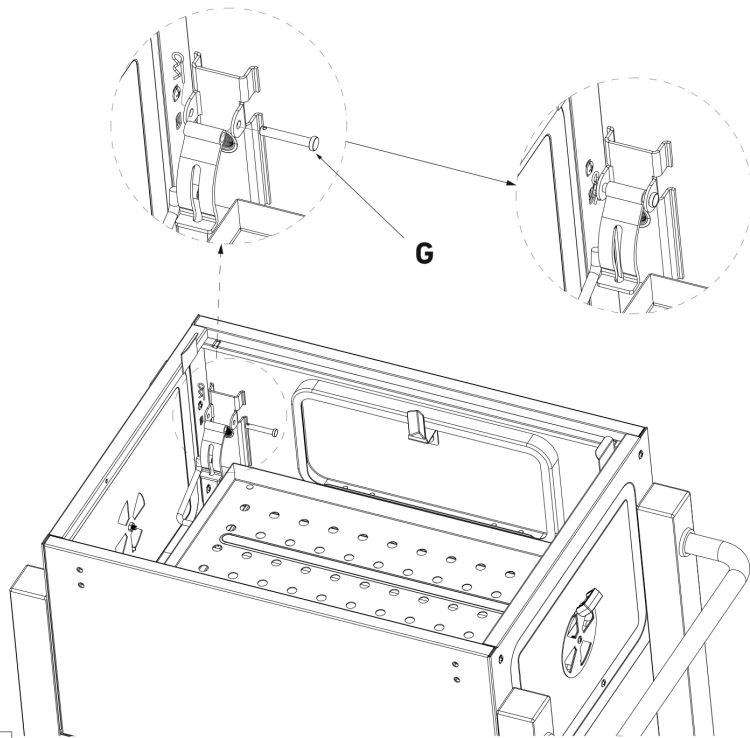



10

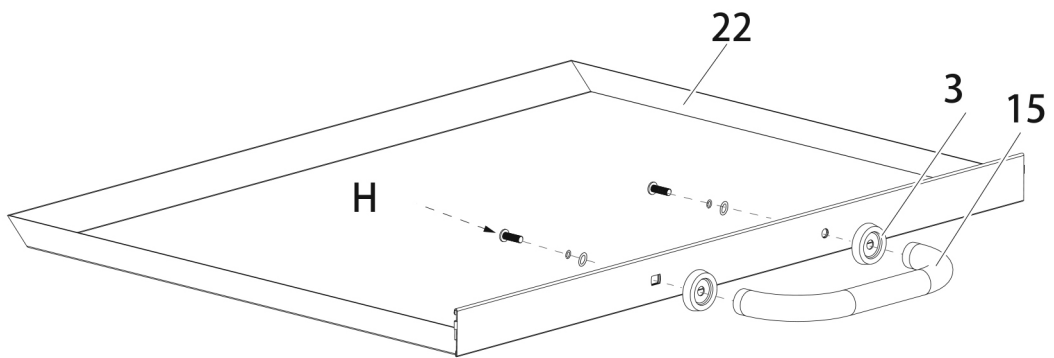

G		Ø6X40	x 1
			x 1

11



H			M6X40	x 2
			φ 6X16	x 2
			φ 6	x 2

12

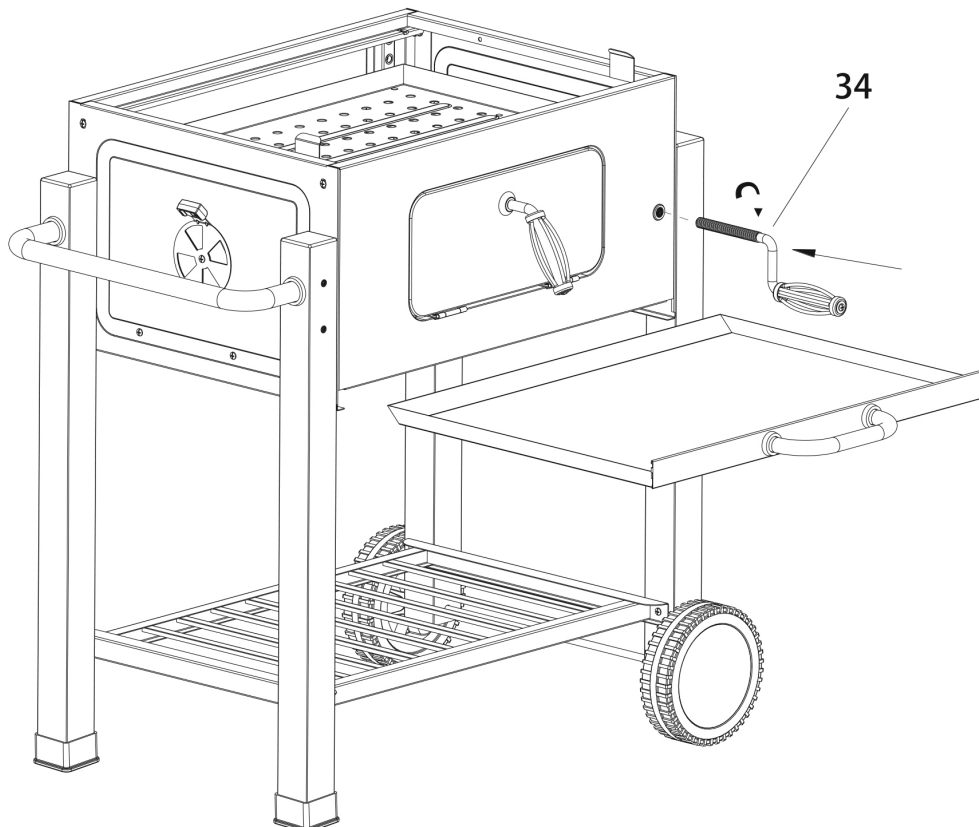

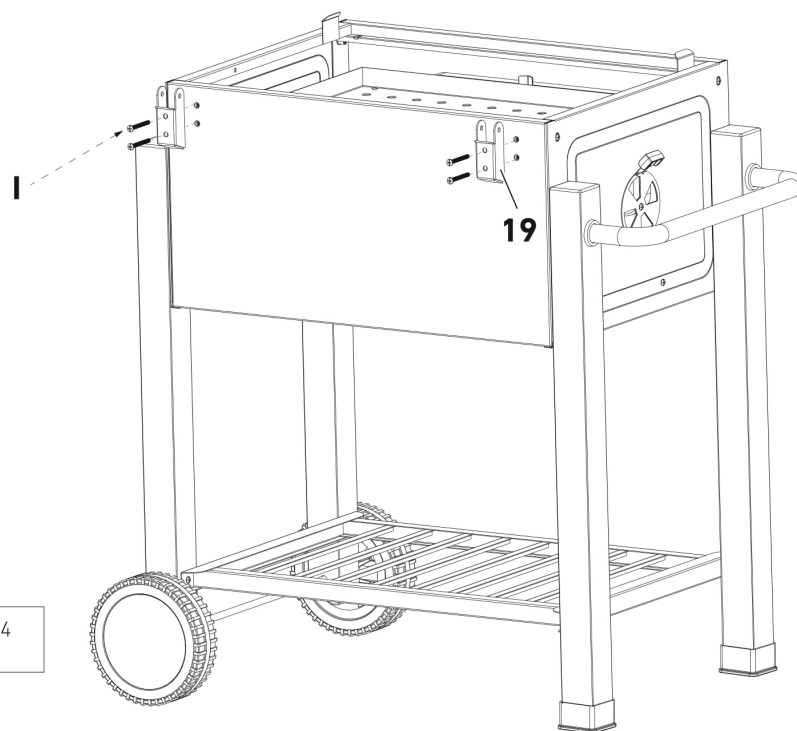

13



I		M6X40	x 4
----------	---	-------	-----

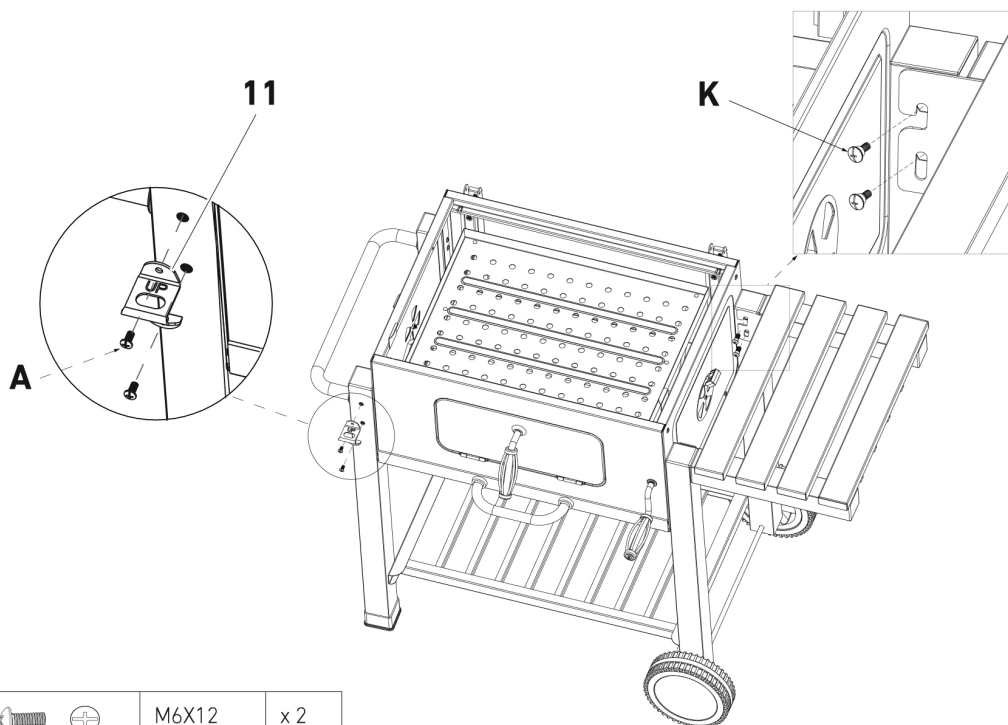





14

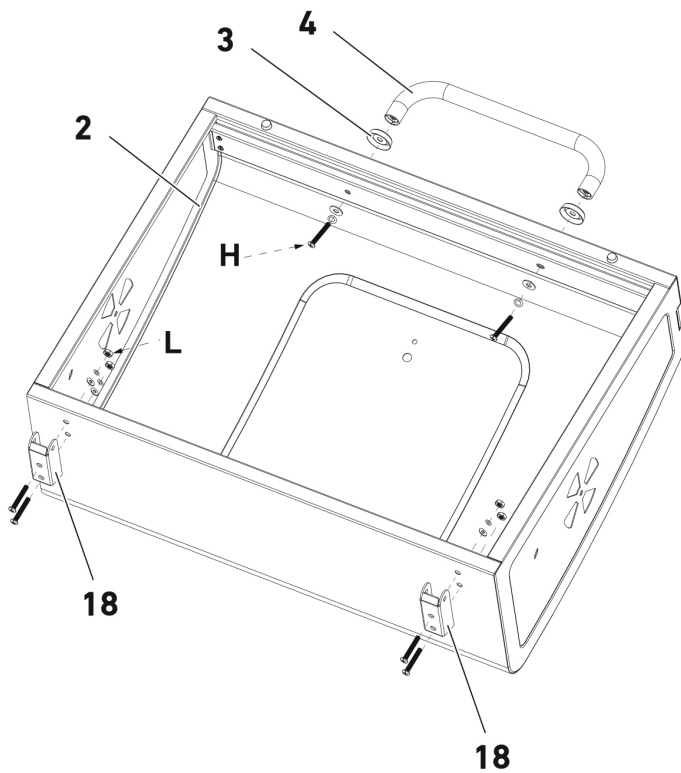

A		M6X12	x 2
K		M6	x 4





15

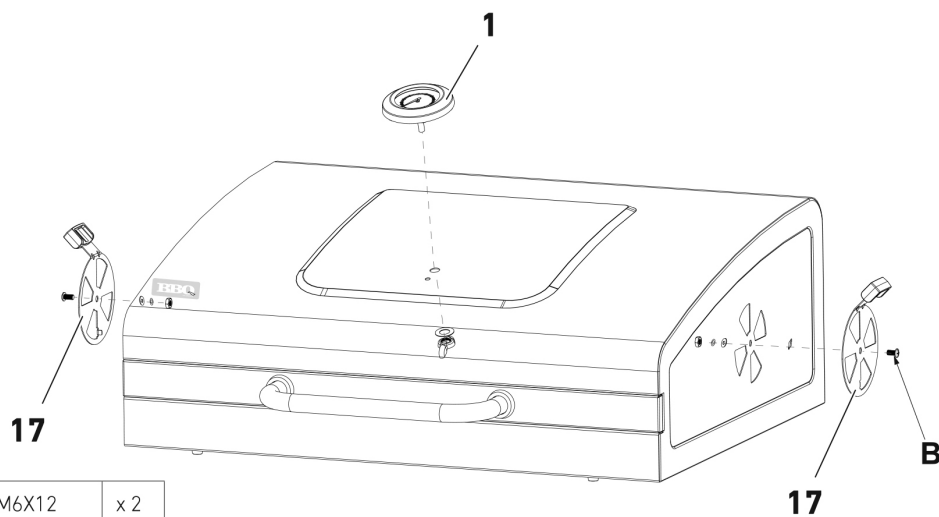

H		M6X40	x 2
		Ø6X16	x 2
		Ø6	x 2
L		M6X40	x 4
		Ø6X16	x 4
		Ø6	x 4
		M6	x 4



16

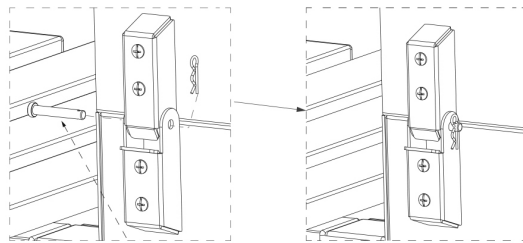
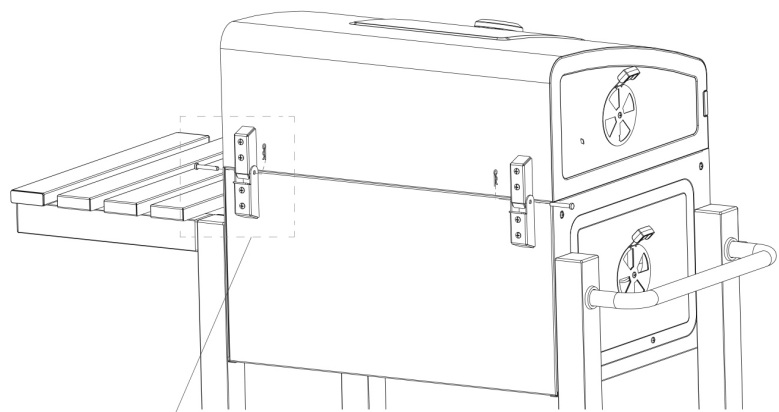

B		M6X12	x 2
		Ø6X16	x 2
		Ø6	x 2
		M6	x 2

17



G		Ø6X40	x 2
			x 2

G

18

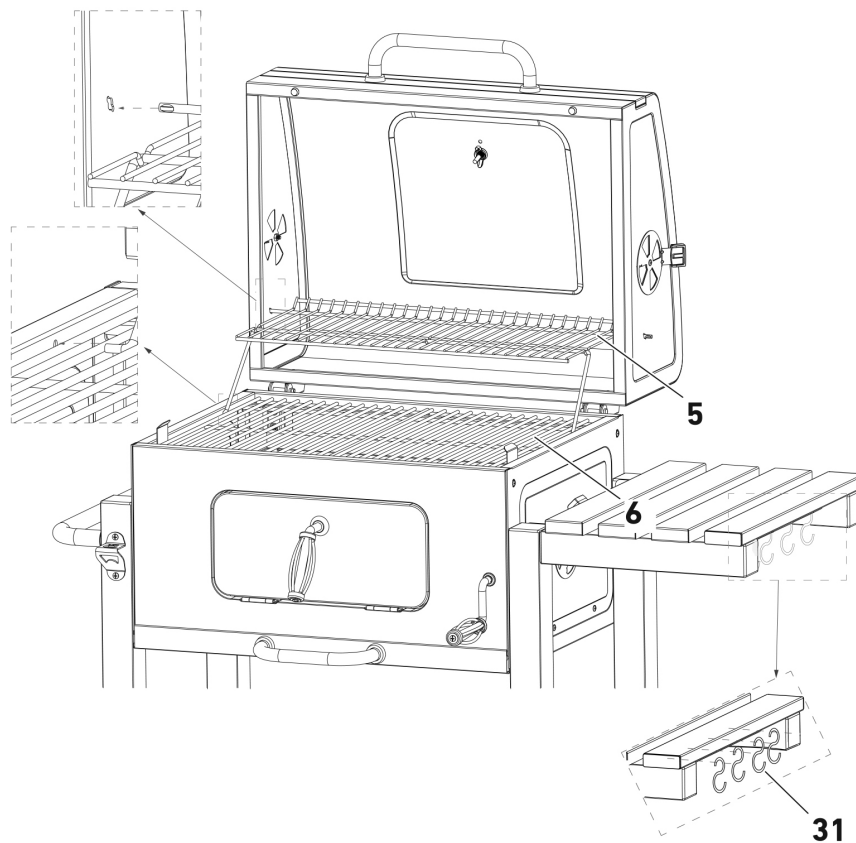

5

6

31

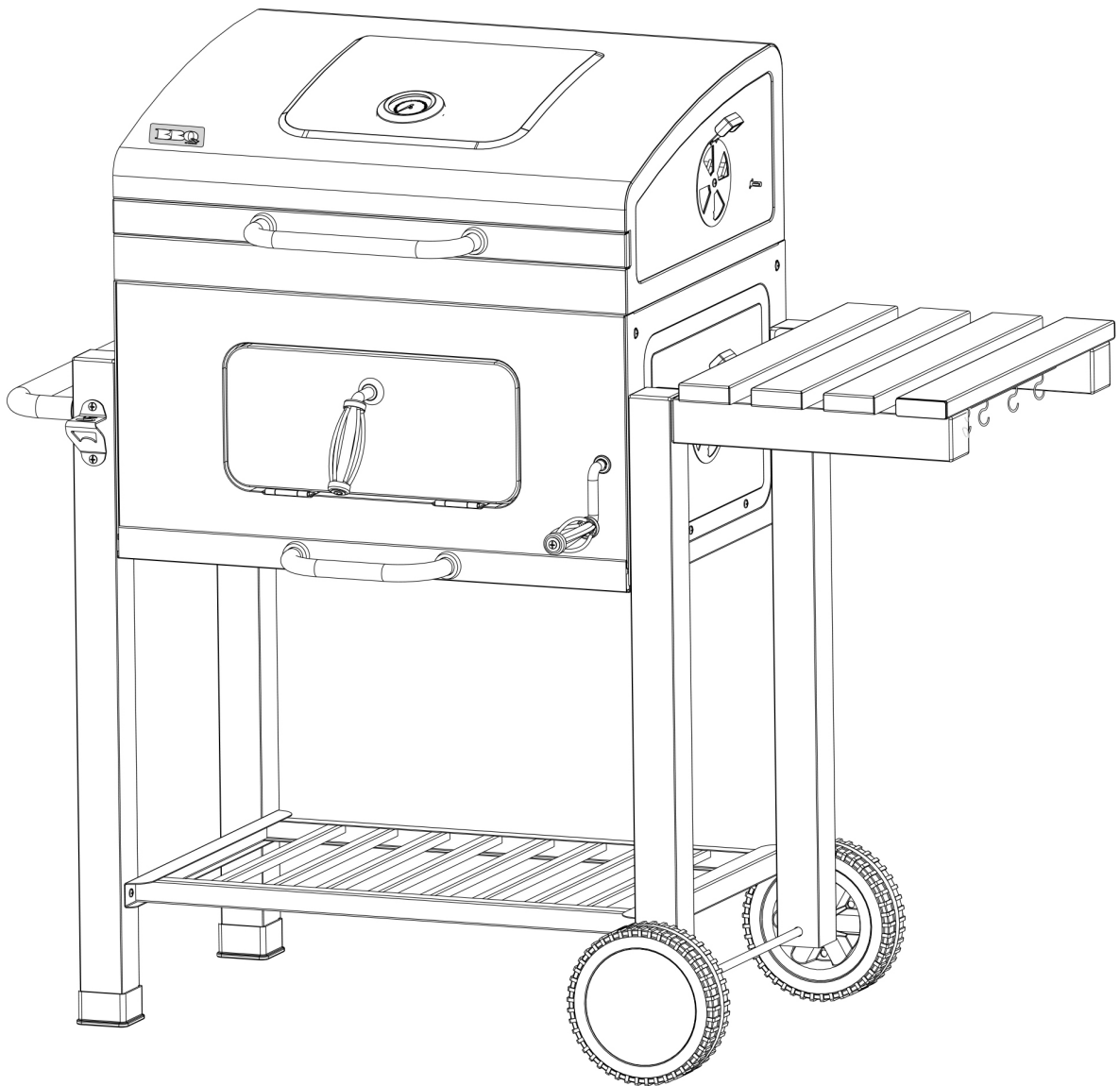

SÄKERHETSANVISNINGAR

VARNING!

- **Grillen blir mycket varm, flytta den inte när den är tänd.**
- **Grillen får inte användas inomhus!**
- **Använd inte alkohol eller bensin för att tända grillen. Spruta inte någon form av lättantändlig vätska över grillkol eller briketter som redan tänts. Använd enbart tändmedel som uppfyller EN 1860-3.**
- **Håll barn och husdjur på behörigt avstånd från grillen.**

ÖVRIGA SÄKERHETSANVISNINGAR

- Använd aldrig vatten för att kontrollera eller släcka elden.
- Lägg på locket och stäng luftventilerna när grillningen är avslutad.
- Använd grillvantar för att undvika brännskador vid grillning.
- Varmt grillkol eller varma briketter får inte kastas i soptunnor, där någon kan trampa på dem eller där det råder risk för eldsvåda. Låt briketterna slockna helt innan de kastas bort.
- Ställ inte grillen i t.ex. ett förråd innan den har slocknat helt.
- Se till att lättantändliga vätskor och tryckbehållare inte finns inom den tända grillens område.
- Om elektrisk tändare används ska dess nätsladd hållas borta från grillens varma ytor.
- Grillen är inte avsedd som värmeelement och får under inga omständigheter användas inomhus.
- Rengör grillen regelbundet för att säkerställa avsedd funktion.
- Grillen ska stå stabilt på ett fast och plant

underlag när den används. Placera grillen på minst 3 meters avstånd från träd och brännbart material.

- Endast grillkol och briketter får användas för uppvärmning.
- Kontrollera att kolen glöder helt och hållet före grillning, det tar minst 30 minuter. Grillning kan påbörjas först när briketterna/grillkolen har jämn glöd och en grå hinna som täcker dem.

OBS!

- **Briketterna/grillkolen ska alltid placeras på kolfatet i grillens botten. Annars riskerar grillen att ta skada. Använd inte för mycket briketter/grillkol, ett lager räcker.**
- **Kolgallret kan upplevas lite snett när det ingen kol/briketter ligger på. Detta är inget fel, utan när kol och briketter läggs på så rätar den sig.**

Symboler







Använd inte produkten i slutna utrymmen och/eller utrymmen avsedda för längre vistelse, som hus, tält, husvagn, husbil, båt etc. Risk för dödsfall till följd av kolmonoxidförgiftning.

















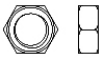

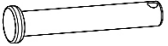

BESKRIVNING

- | | |
|-------------------------|------|
| 1. Termometer | 1 st |
| 2. Lock, | 1 st |
| 3. Bricka till handtag, | 4 st |
| 4. Handtag till lock | 1 st |
| 5. Varmhållningsgaller | 1 st |
| 6. Grillgaller | 2 st |

7.	Handtag till grill	1 st
8.	Bricka till handtag	2 st
9.	Bakre panel	1 st
10.	Sidopanel vänster	1 st
11.	Kapsylöppnare	1 st
12.	Långt bakre ben	1 st
13.	Långt främre ben	1 st
14.	Frontpanel	1 st
15.	Handtag till askbehållare	1 st
16.	Gummifot till ben	2 st
17.	Ventilgaller	4 st
18.	Övre gångjärn	2 st
19.	Nedre gångjärn	2 st
20.	Sidopanel höger	1 st
21.	Kolgaller	1 st
22.	Askbehållare	1 st
23.	Hylla	1 st
24.	Hjulkåpa	2 st
25.	Hjul	2 st
26.	Hjulaxel	1 st
27.	Lås till lucka	1 st
28.	Bricka till låsvred	1 st
29.	Låsvred till lucka	1 st
30.	Sidobord	1 st
31.	Krok	4 st
32.	Kort bakre ben	1 st
33.	Långt bakre ben	1 st
34.	Vred för justering av kolgaller	1 st

BILD 1**Skruvvar, muttrar etc.**

			Antal
A	M6x12		18
B	M6x12		4
	Ø6x16		4
	Ø6		4
	M6		4

C	M6x20		8
	Ø6x16		8
	Ø6		8
D	M10		2
E	M6x80		2
	Ø6x16		2
	Ø6		2
F	M6		1
	Ø6x16		1
	Ø6		1
G	Ø6x40		3
			3
H	M6x40		4
	Ø6x16		4
	Ø6		4
I	M6x40		4
J			1
K	M6		4
L	M6x40		4
	Ø6x16		4
	Ø6		4
	M6		4

MONTERING

- Ta ut alla delar ur förpackningen och sortera dem innan monteringen påbörjas.
- Montera grillen på ett jämnt underlag.
- Se illustrationerna för korrekt monteringsordning.

BILD 2 – 19

SIKKERHETSANVISNINGER

ADVARSEL!

- **Grillen blir svært varm, ikke flytt den når den er tent.**
- **Grillen skal ikke brukes innendørs!**
- **Ikke bruk alkohol eller bensin til å tenne grillen. Ikke sprut noen form for lettantennelig væske over grillkull eller briketter som allerede er tent. Bruk kun tennmiddel som oppfyller EN 1860-3.**
- **Hold barn og husdyr på forsvarlig avstand fra grillen.**

ØVRIGE SIKKERHETSANVISNINGER

- Bruk aldri vann til å kontrollere eller slukke ilden.
- Legg på lokket og steng lufterventilene når grillingen er avsluttet.
- Bruk grillvanter for å unngå brannskader når du griller.
- Varmt grillkull eller varme briketter skal ikke kastes i søppelbøtter, på steder hvor noen kan tråkke på dem eller på brannfarlige steder. La brikettene slukke helt før du kaster dem.
- Ikke sett grillen i f.eks. en bod før den har sluknet helt.
- Se til at lettantennelige væsker og trykkbeholdere ikke står i nærheten av den tente grillen.
- Hvis du bruker en elektrisk tenner, må strømledningen holdes unna grillens varme deler.
- Grillen er ikke beregnet for bruk som varmeelement, og skal ikke under noen omstendigheter brukes innendørs.
- Rengjør grillen regelmessig for å sikre at den fungerer som den skal.
- Grillen skal stå stabilt på et fast og plant underlag når den er i bruk. Plasser grillen

minst 3 meters unna tre og annet brennbart materiale.

- Ikke bruk noe annet enn grillkull og briketter til oppvarming.
- Kontroller at kullet gløder helt før du begynner å grille. Det tar minst 30 minutter. Du kan begynne å grille først når brikettene/grillkullet har en jevn glød og er dekket av en grå hinne.

MERK!

- **Brikettene/grillkullet skal alltid plasseres på kullfatet i bunnen av grillen. Noe annet kan skade grillen. Ikke bruk for mye briketter/grillkull, ett lag er nok.**
- **Kullgitteret kan virke litt skjevt når det ikke ligger kull/briketter på. Dette er ikke en feil, det retter seg ut når man legger på kull/briketter.**

Symboler







<p>Grillen må aldri ikke brukes i et lukket og/ eller bebodd område, som i hus, telt, campingvogn, bobil eller båt. Fare for karbonmonoksidforgiftning med døden som følge.</p>			



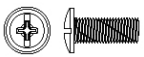











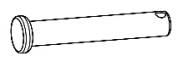

BESKRIVELSE

1. Termometer	1 stk.
2. Lokk,	1 stk.
3. Skive til håndtak,	4 stk.
4. Håndtak til lokk	1 stk.
5. Varmholdingsrist	1 stk.
6. Grillrist	2 stk.
7. Håndtak til grill	1 stk.

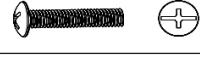
8.	Skive til håndtak	2 stk.
9.	Bakre panel	1 stk.
10.	Sidepanel venstre	1 stk.
11.	Flaskeåpner	1 stk.
12.	Langt bakre ben	1 stk.
13.	Langt fremre ben	1 stk.
14.	Frontpanel	1 stk.
15.	Håndtak til askebeholder	1 stk.
16.	Gummifot til ben	2 stk.
17.	Ventilrist	4 stk.
18.	Øvre hengsel	2 stk.
19.	Nedre hengsel	2 stk.
20.	Sidepanel høyre	1 stk.
21.	Kullrist	1 stk.
22.	Askebeholder	1 stk.
23.	Hylle	1 stk.
24.	Hjuldeksel	2 stk.
25.	Hjul	2 stk.
26.	Hjulaksel	1 stk.
27.	Lås til luke	1 stk.
28.	Skive til låseknot	1 stk.
29.	Låseknot til luke	1 stk.
30.	Sidebord	1 stk.
31.	Krok	4 stk.
32.	Kort bakre ben	1 stk.
33.	Langt bakre ben	1 stk.
34.	Håndbremse for justering av strekningen	1 stk.

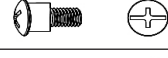
BILDE 1**Skruer, muttere etc.**

			Antall
A	M6 x 12		18
B	M6 x 12		4
	Ø6 x 16		4
	Ø6		4
	M6		4
C	M6 x 20		8
	Ø6 x 16		8
	Ø6		8

D	M10		2
E	M6 x 80		2
	Ø6 x 16		2
	Ø6		2
F	M6		1
	Ø6 x 16		1
	Ø6		1
G	Ø6 x 40		3
			3
H	M6 x 40		4
	Ø6 x 16		4
	Ø6		4
I	M6 x 40		4
J			1
K	M6		4
L	M6 x 40		4
	Ø6 x 16		4
	Ø6		4
	M6		4

MONTERING

- Ta alle delene ut av emballasjen og sorter dem før du starter på monteringen.
- Monter grillen på et jevnt underlag.
- Se illustrasjonene for korrekt monteringsanvisning.

BILDE 2 – 19

ZASADY BEZPIECZEŃSTWA

OSTRZEŻENIE!

- **Grill mocno się nagrzewa. Nie przesuwaj go, gdy jest rozpalony.**
- **Grilla nie wolno używać w pomieszczeniach!**
- **Do rozpalania grilla nie stosuj alkoholu ani benzyny. Nie rozpylaj żadnych łatwopalnych cieczy nad rozżarzonym węglem i brykietami. Korzystaj wyłącznie z rozpałek, które spełniają wymogi normy EN 1860-3.**
- **Dzieci i zwierzęta domowe powinny przebywać w bezpiecznej odległości od grilla.**

POZOSTAŁE ZASADY BEZPIECZEŃSTWA

- Nigdy nie używaj wody do kontrolowania ognia ani do jego gaszenia.
- Po zakończeniu grillowania nałóż pokrywę i zamknij otwory wentylacyjne.
- Aby uniknąć oparzeń, korzystaj z rękawic do grilla.
- Nie wrzucaj rozżarzonych kawałków węgla i brykietów do pojemników na odpady. Nie pozostawiaj ich też ich w miejscach, gdzie ktoś mógłby na nie nadepnąć, ani w miejscach zagrożonych pożarem. Przed wyrzuceniem brykietów zaczekaj, aż całkowicie się wypalą.
- Nie odstawiaj grilla np. do schowka, zanim żar całkowicie nie wygaśnie.
- Upewnij się, że w okolicy rozpalonego grilla nie ma łatwopalnych cieczy ani pojemników pod ciśnieniem.
- Jeżeli korzystasz z zapalnika elektrycznego, trzymaj jego przewód zasilający z dala od rozgrzanych powierzchni grilla.
- Grill nie jest przeznaczony do stosowania jako grzejnik i pod żadnym pozorem nie można go używać w pomieszczeniach.

- Czyść grill regularnie, aby zapewnić jego prawidłowe działanie.
- Podczas korzystania z grilla powinien on stać stabilnie na zwartym i płaskim podłożu. Umieść grill w odległości co najmniej 3 metrów od drzew i materiałów palnych.
- Jako paliwo wolno stosować wyłącznie węgiel lub brykiety.
- Przed rozpoczęciem grillowania sprawdź, czy węgiel całkowicie się rozżarzył – potrwa to co najmniej 30 minut. Grillowanie można rozpocząć dopiero wtedy, gdy brykiety lub węgiel będą równomiernie rozżarzone i pokryte szarym nalotem.

UWAGA!

- **Brykiety/węgiel umieszczaj zawsze na znajdującej się na spodzie grilla półce na węgiel. W przeciwnym razie może dojść do uszkodzenia grilla. Nie używaj zbyt wiele węgla/brykietów, wystarczy jedna warstwa.**
- **Ruszt węglowy może wydawać się lekko skrzywiony, gdy nie leżą na nim brykiety lub węgiel. Nie jest to wada produktu. Ruszt wyprostuje się, gdy zostaną na nim umieszczone brykiety lub węgiel.**

Symbole







Nie używaj grilla w ciasnych miejscach lub pomieszczeniach mieszkalnych, takich jak domy, namioty, przyczepy kempingowe, kampery czy łódzie. Niebezpieczeństwo śmierci na skutek zatrucia tlenkiem węgla.





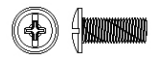





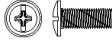



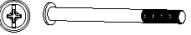

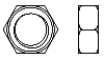

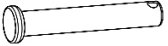

OPIS

1.	Termometr	1 szt.
2.	Pokrywa	1 szt.
3.	Podkładka do uchwytu	4 szt.
4.	Uchwyt pokrywy	1 szt.
5.	Ruszt do podgrzewania	1 szt.
6.	Ruszt grillowy	2 szt.
7.	Uchwyt grilla	1 szt.
8.	Podkładka do uchwytu	2 szt.
9.	Panel tylny	1 szt.
10.	Lewy panel boczny	1 szt.
11.	Otwieracz do butelek	1 szt.
12.	Długa noga tylna	1 szt.
13.	Długa noga przednia	1 szt.
14.	Panel przedni	1 szt.
15.	Uchwyt do pojemnika na popiół	1 szt.
16.	Gumowa stopka do nogi	2 szt.
17.	Kratka wentylacyjna	4 szt.
18.	Zawias górny	2 szt.
19.	Zawias dolny	2 szt.
20.	Prawy panel boczny	1 szt.
21.	Ruszt węglowy	1 szt.
22.	Pojemnik na popiół	1 szt.
23.	Półka	1 szt.
24.	Ostona koła	2 szt.
25.	Koło	2 szt.
26.	Oś kół	1 szt.
27.	Blokada drzwiczek	1 szt.
28.	Podkładka do pokrętki blokującego	1 szt.
29.	Pokrętło blokujące do drzwiczek	1 szt.
30.	Blat boczny	1 szt.
31.	Wieszak	4 szt.
32.	Krótką noga tylna	1 szt.
33.	Długa noga tylna	1 szt.
34.	Pokrętło do regulacji rusztu węglowego	1 szt.

RYS. 1

Śruby, nakrętki itp.

			Liczba
A	M6x12		18
B	M6x12		4
	Ø 6 x 16		4
	Ø 6		4
	M6		4

C	M6x20		8
	Ø 6 x 16		8
	Ø 6		8
D	M10		2
E	M6x80		2
	Ø 6 x 16		2
	Ø 6		2
F	M6		1
	Ø 6 x 16		1
	Ø 6		1
G	Ø 6 x 40		3
			3
H	M6x40		4
	Ø 6 x 16		4
	Ø 6		4
I	M6x40		4
J			1
K	M6		4
L	M6x40		4
	Ø 6 x 16		4
	Ø 6		4
	M6		4

MONTAŻ

- Wyjmij wszystkie części z opakowania i posortuj je przed rozpoczęciem montażu.
- Zmontuj grill na równym podłożu.
- Aby zachować właściwą kolejność montażu, zob. ilustracje.

RYS. 2 – 19

SAFETY INSTRUCTIONS

WARNING!

- **The grill gets very hot, do not move it when it is lit.**
- **Do not use the grill indoors.**
- **Do not use alcohol or petrol to light the grill. Do not spray any form of flammable liquid over the charcoal or briquettes when they have already been lit. Only use firelighters that comply with EN 1860-3.**
- **Keep children and pets at a safe distance from the grill.**

OTHER SAFETY INSTRUCTIONS

- Never use water to control or extinguish the flames.
- Put the lid on and close the air valves when you have finished grilling.
- Wear grill gloves to avoid burn injuries when grilling.
- Do not throw hot charcoal or briquettes into rubbish bins, or where someone could tread on them, or anywhere else where they could start a fire. Make sure briquettes are completely extinguished before discarding them.
- Do not put the grill away, in your garden shed for example, before it has completely gone out.
- Keep flammable liquids and pressure containers at a safe distance from the barbecue area.
- When using an electric lighter, keep the cable well away from the hot surfaces on the grill.
- The grill is not intended to be used as a heater, and must never be used indoors under any circumstances.
- Clean the grill regularly to ensure that it will keep on working properly.

- The grill must stand on a stable and level surface when in use. Place the grill at a distance of at least 3 metres from any trees or combustible material.
- Only use charcoal and briquettes for the grilling.
- Check that the charcoal is red-hot before grilling, it takes at least 30 minutes. Start grilling when the briquettes/charcoal have a uniform red-hot glow with a thin crust of grey ash over them.

NOTE:

- **Always put the briquettes/charcoal in the charcoal tray in the bottom of the grill. Otherwise there is a risk of damaging the grill. Do not use too much charcoal/briquettes, one layer is enough.**
- **The charcoal rack may appear to be somewhat skew when it does not contain any charcoal/briquettes. It will straighten out when charcoal and briquettes are put on it.**

Symbols

Do not use the barbecue in a confined and/or habitable space e.g. houses, tents, caravans, motor homes, boats. Danger of carbon monoxide poisoning fatality.			





DESCRIPTION











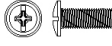



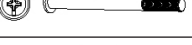





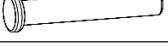

- | | |
|-----------------------|---|
| 1. Thermometer | 1 |
| 2. Lid, | 1 |
| 3. Washer for handle, | 4 |
| 4. Handle for lid | 1 |
| 5. Warming rack | 1 |

- 6. Grill rack 2
- 7. Handle for grill 1
- 8. Washer for handle 2
- 9. Back panel 1
- 10. Side panel, left 1
- 11. Bottle opener 1
- 12. Long back leg 1
- 13. Long front leg 1
- 14. Front panel 1
- 15. Handle for ash tray 1
- 16. Rubber foot for leg 2
- 17. Ventilator 4
- 18. Top hinge 2
- 19. Bottom hinge 2
- 20. Right side panel 1
- 21. Charcoal rack 1
- 22. Ash tray 1
- 23. Shelf 1
- 24. Wheel cap 2
- 25. Wheel 2
- 26. Wheel axle 1
- 27. Lock for lid 1
- 28. Washer for knob 1
- 29. Knob for lid 1
- 30. Side table 1
- 31. Hook 4
- 32. Short back leg 1
- 33. Long back leg 1
- 34. Knob to adjust charcoal rack 1

FIG. 1

Screws, nuts etc.

			Qty
A	M6x12		18
B	M6x12		4
	Ø6x16		4
	Ø6		4
	M6		4

C	M6x20		8
	Ø6x16		8
	Ø6		8
D	M10		2
E	M6x80		2
	Ø6x16		2
	Ø6		2
F	M6		1
	Ø6x16		1
	Ø6		1
G	Ø6x40		3
			3
H	M6x40		4
	Ø6x16		4
	Ø6		4
I	M6x40		4
J			1
K	M6		4
L	M6x40		4
	Ø6x16		4
	Ø6		4
	M6		4

ASSEMBLY

- Remove all the parts from the packaging and sort before assembly.
- Assemble the grill on a level surface.
- See diagrams for correct order of assembly.

FIG. 2 – 19