

EN Appropriate for the listed vehicles - **FR** Les barres de toit ne doivent pas être utilisées sur des véhicules autres que spécifiés - **ES** Válido para la lista adjunta de vehículos - **DE** Passend für die gelisteten - **IT** Appropriare per veicolo
NL Geschikt voor voertuig - **PT** Apropriado aos seguintes veículos - **PL** Pasuje do samochodów
HU Megfelelő gépjármű - **NO** Produktet er kun beregnet for angitte kjøretøy - **RO** Convenabil pentru vehicul - **ET** Sobib loetletud sõidukitele
LT Tinka nurodytiems transporto priemonėms - **SE** Produkten är endast avsedd för angivna fordon - **BG** Релсите за багажник на покрива не трябва да се използват при автомобили, различни от посочените
LV Piemērots norādītajiem transportlīdzekļiem - **FI** Tuote on tarkoitettu vain ilmoitetuille ajoneuvoille - **GR** Για το οχήμα - **DK** Egnnet til køretøjer



	1	2	X	Y
ALFA ROMEO				
GIULIETTA	5	10 ->	60	49+
AUDI				
A3 SPORTBACK ⁽¹³⁾	5	20 ->	60	49+
CITROËN				
C3	5	17 ->	60	49+
C4 ⁽¹³⁾	5	21 ->	60	49+
C4 ⁽¹³⁾	5	10/10 -> 10/20	60	49+
C4-X ⁽¹³⁾	4	23 ->	60	49+
ë-C4 ⁽¹³⁾	5	21 ->	60	49+
ë C4-X ⁽¹³⁾	4	23 ->	60	49+
FIAT				
600 ⁽¹³⁾	5	23 ->	60	49+
FORD				
C-MAX	5	10/10 -> 11	75	52+
MONDEO III	4	06/07 -> 08/14	75	49+
MONDEO III	5	06/07 -> 08/14	75	49+
LANCIA				
DELTA ⁽¹³⁾	5	06/08 ->	75	49+
YPSILON ⁽¹³⁾	5	06/11 ->	75	49+
OPEL				
ASTRA (K)	5	10/15 ->	60	49+
INSIGNIA	4	09 -> 03/17	75	52+
INSIGNIA	5	09 -> 03/17	75	52+
INSIGNIA GRAND SPORT	5	04/17 ->	75	52+
PEUGEOT				
208 ⁽¹³⁾	5	12 -> 09/19	60	49+
508	4	11 -> 08/18	75	49+
RENAULT				
ARKANA ⁽¹³⁾	5	20 ->	60	49+
AUSTRAL	5	22 ->	60	52+
GRAND SCENIC ⁽¹³⁾	5	04/09 -> 10/16	75	52+
MEGANE III ⁽¹³⁾	5	11/08 -> 11/15	75	49+
MEGANE III Estate / Break ⁽²⁾⁽¹³⁾	5	06/09 -> 08/16	75	49+
SCENIC III ⁽¹³⁾	5	06/09 -> 08/16	75	52+
SEAT				
TOLEDO	5	11/12 ->	75	49+
SKODA				
FABIA (MKII) ⁽¹⁾	5	05/07 -> 11/14	75	49+
FABIA (MKIII) ⁽¹³⁾	5	12/14 -> 20	60	49+
FABIA IV ⁽¹³⁾	5	21 ->	60	49+
OCTAVIA II	4	04/04 -> 02/13	75	46+
OCTAVIA II ⁽¹⁾	5	06/04 -> 02/13	75	46+
OCTAVIA III ⁽¹³⁾	4	03/13 -> 06/20	60	49+
OCTAVIA IV ⁽¹³⁾	5	20 ->	60	49+
RAPID	5	12 ->	75	49+
RAPID SPACEBACK ⁽¹³⁾	5	13 ->	60	49+
SCALA ⁽¹³⁾	5	19 ->	60	49+
SUPERB III	5	06/15 ->	60	52+
SUPERB IV ⁽¹³⁾	5	23 ->	60	49+
VOLKSWAGEN				
PASSAT (B8)	4	11/14 ->	60	52+
VOLVO				
S60	4	07/10 ->	75	49+
V50 ⁽²⁾	5	04 ->	75	52+

□ = Doors / Portes / Puertas / Türen / Porte / Deurs / Portas / Drzwi / Ajtók / Dører / Uși / Uksed / Durys / Dörrar / врати / Durvis / Ovet / πόρτες / Dore

(1) Except station wagon/estate / Sauf break / Excepto break / Außer Kombi / Salvo break / Behalve stationcars / Excepto break / Z wyjątkiem breakn / Kombit kivéve / Unntatt stasjonsvogn / Exceptând break / Vájlja arvatud universaal / Išskyrus universal / Förutom kombi / C исключение на break / Izņemot universālu / Paitsi farmari/ Χωρίς break / Undtagen stationcars

(2) Vehicle without original longitudinal bars / Véhicule sans barres longitudinales d'origine / Vehículo sin barras longitudinales de origen / Fahrzeuge ohne original-dachreling / Veicoli senza barre longitudinali originali / Voertuig zonder originele longitudinale stangen / Veículo sem barras longitudinais de origem / Samochód bez oryginalnych relingów / Gyárilag hosszirányú rudak nélkül szerelt gépjármű / Kjøretøy uten original-reling / Vehicul fără bare longitudinale originale / Sõidukid ilma originaalsete pikisuunaliste liistudeta / Transporto priemonės be originalių išilginių skersinių / Fordon utan original-reling/ Автомобил без продольных дуг, предусмотренными моделью / Transportlidzekļi bez oriģinālajiem garenstieņiem / Ajoneuvot ilman alkuperäistä kattokaidetta / Οχήμα χωρίς διαμήκεις μπάρες από εργοστασιακή κατασκευή / Køretøj uden originale langsgående stænger

(13) Except glass roof / Sauf toit en verre / Excepto techo en vidrio / Außer Glasdach / Tranne tetto di vetro / Behalve glazen dak / Excepto tejadilho de vidro / Z wyłączeniem szklanego dachu / Kivéve az üvegtetőket / Ikke glasatak / Cu excepția acoperișurilor din sticlă / Vájlja arvatud klaaskatus / Išskyrus stiklinį stogą / Ej glasatak / За исключением стеклянной крыши / Izņemot stikla jumtu / Ei lasikattoa / Εκτός από γυάλινη οροφή / Med undtagelse af glas tag

Mont Blanc®

MB RoofBars AMC KIT FIX POINT FOOT 5122

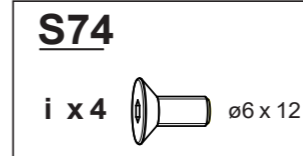
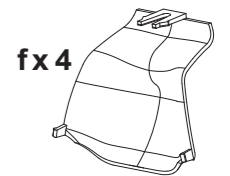
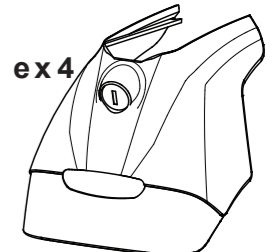
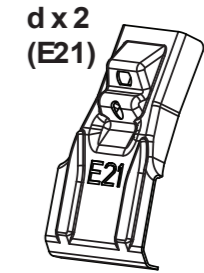
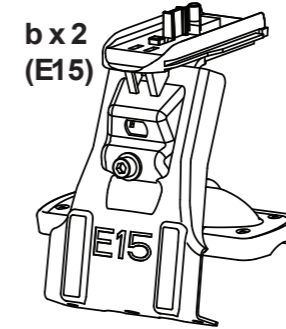
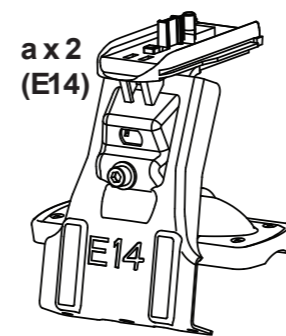

MONT BLANC France
35417 SAINT-MALO CEDEX
France
Type : BARRE DE TOIT / ROOF RACK
Modél : MB RoofBar AMC 5122
Max Load : 75 KG
Pxxxxxxxxx
OF: xxxxxx

j x 1



Pour en savoir plus :
www.quefairedemesdechets.fr

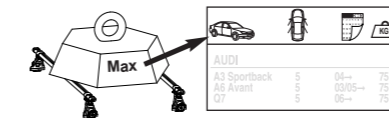

P.8

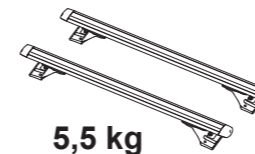

Réf. Imp.: 057002/A25-2



Mont Blanc France
24-30 Rue Claude Bernard - C.S. 61768
35417 Saint Malo Cédex - France
Office : +33 (0)2 99 21 12 70
Fax : +33 (0)2 99 21 12 71

www.montblancgroup.com



EN Keep these instructions for future use.
FR Garder cette notice pour les utilisations futures.
ES Guardar este manual para futuras utilizaciones.
DE Die Anleitung zur späteren Benutzung aufbewahren.
IT Conservare queste istruzioni per ogni ulteriore consultazione.
NL Bewaar deze gebruiksaanwijzing voor toekomstige raadpleging.
PT Guardar este manual para as utilizações futuras.
PL Zachować instrukcję w przypadku użytkowania w przyszłości.
HU Őrizze meg ezt a használati utasítást későbbi felhasználás céljából.
NO Behold denne informasjonen for fremtidig bruk.
RO Păstrați instrucțiunile pentru consultarea lor ulterioară.
ET Hoidke neid juhiseid edaspidiseks kasutamiseks.
LT Laikykite šias instrukcijas būsimam naudojimui.
SE Behåll denna information för framtida bruk.
BG Запазете настоящата бележка за бъдещи справки.
LV Saglabājiet šīs instrukcijas turpmāķai lietošanai.
FI Säilytä tämä tieto tulevaa käyttöä varten.
GR Φυλάξτε αυτό το εγχειρίδιο οδηγιών για μελλοντικές χρήσεις.
DK Gem denne vejledning til senere brug.

1

AUDI		
A3 SPORTBACK	5	20->
CITROËN		
C3	5	17->
C4	5	10/10->20
C4-X	5	21->
6-C4	4	23->
6-C4-X	5	21->
6-C4-X	4	23->
FORD		
C-Max	5	10/10->11
LANCIA		
Delta	5	06/08->
Ypsilon	5	06/11->
OPEL		
ASTRA (K)	5	10/15->
PEUGEOT		
208	5	2012->18
508	4	11->19
RENAULT		
Arkana	5	20->
Grand Scenic	5	04/09->16
Scenic III	5	06/09->16
SEAT		
Toledo	5	11/12->
SKODA		
FABIA (MKIII)	5	12/14->20
Fabia (MKIV)	5	21->
Octavia III	5	03/13->20
Octavia IV	5	20->
Rapid	5	12/02->
Rapid Spaceback	5	13->
Scala	5	19->
Superb III	5	06/15->
Superb IV	5	23->
VOLKSWAGEN		
PASSAT (B8)	4	11/14->
VOLVO		
S40	4	05->
S60	4	10->
V50	5	05->

2

3 Aluminium Crossbars

Steel Crossbars

4

5

6

CLIC

EN Fitting on vehicles - FR Montage sur véhicule - ES Colocación en vehículos - DE Montagen auf Fahrzeugen
 IT Montaggio su veicoli - NL Montage op voertuigen - PT Montagens em veículos - PL Montowanie na pojazdach HU
 Felszerelés gépjárműre - NO Montering på bilen - RO Montaj pe vehicul - ET Paigaldamine sõidukitele
 LT Montavimas ant transporto priemonių - SE Montering på bilen - BG Монтиране върху автомобила - LV
 Uzstādīšana uz transportlīdzekļiem - FI Asennus autoon - GR Τοποθέτηση στο όχημα - DK Montage på køretøjer

1

x 4

2

8 Nm

Ex. n°17

p.4

x 4

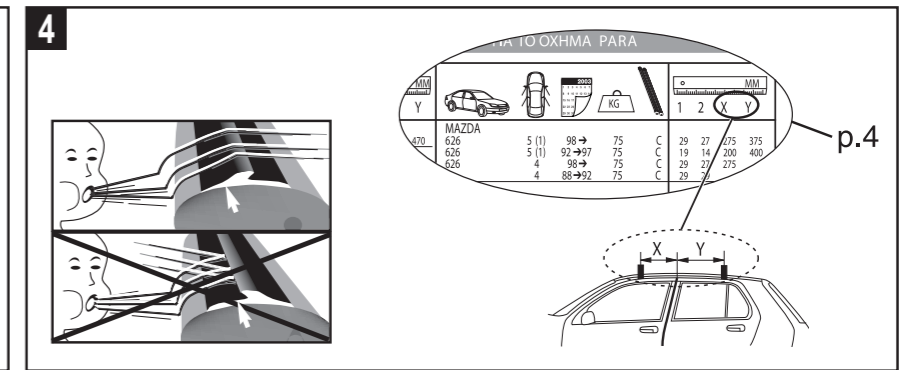
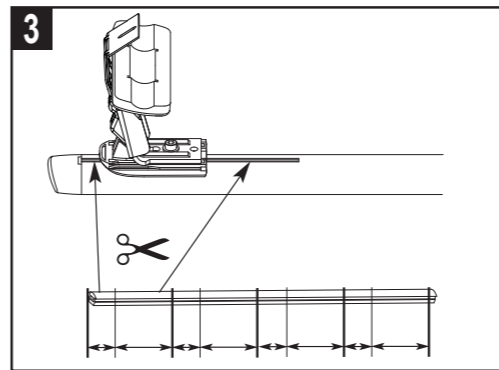

5

Modelo	Altura (mm)	Peso (kg)	Idade	Sexo	Altura do Assento (mm)	Altura da Cabeça (mm)
ALFA ROMEO						
Giulietta	E15	E14				
AUDI						
A3 SPORTBACK	E14	E14				
CITROËN						
C3	E14	E14				
C4 / C4-X / ë C4 / ë C4-X	E14	E14				
FIAT						
600	E14	E21				
FORD						
C-Max	E14	E14				
Mondeo III	E15	E14				
LANCIA						
Delta	E14	E14				
Ypsilon	E14	E14				
OPEL						
Astra (K)	E14	E14				
Insignia	E15	E14				
Insignia Grand Sport	E15	E14				
PEUGEOT						
208	E14	E14				
508	E14	E14				
RENAULT						
Arkana	E14	E14				
Austral	E14	E21				
Megane III	E15	E14				
Megane III Estate	E15	E14				
Scenic III	E14	E14				
Grand Scenic III	E14	E14				
SEAT						
Toledo	E14	E14				
SKODA						
Fabia (MKII)	E14	E21				
Fabia (MKIII)	E14	E14				
Fabia (MKIV)	E14	E14				
Octavia II	E15	E14				
Octavia III	E14	E14				
Octavia IV	E14	E14				
Rapid	E14	E14				
Rapid Spaceback	E15	E14				
Scala	E14	E14				
Superb III	E14	E14				
Superb IV	E14	E14				
VOLKSWAGEN						
Passat (B8)	E14	E14				
VOLVO						
S40	E14	E14				
S60	E14	E14				
V50	E14	E14				

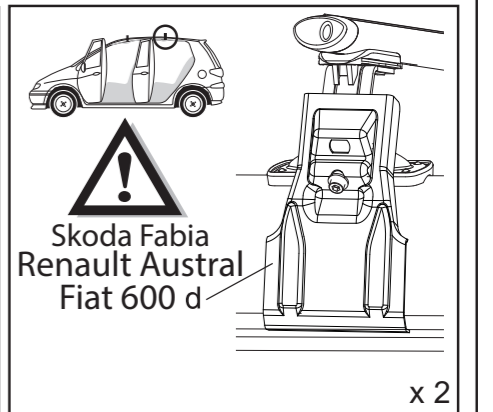
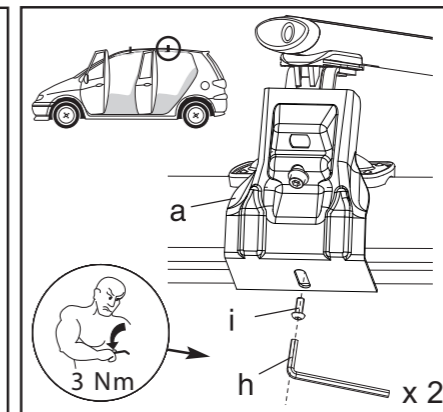
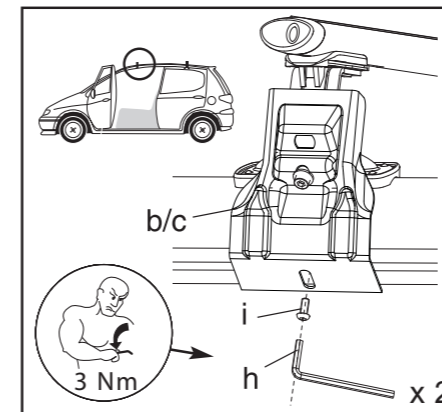

6

Skoda Fabia
Renault Austral
Fiat 600

EN Tighten alternatively left right
FR Serrer alternativement à gauche et à droite
ES Ajustable tirando a derecha e izquierda
DE Abwechselnd nach links und rechts festdrehen
IT Chiudere alternativamente a sinistra e a destra
NL Afwisselend links/rechts vastzetten
PT Enroscar alternadamente à esquerda e à direita
PL Montować najpierw lewą stronę a następnie prawą
HU Szorítsa meg a bal és a jobb oldalon felváltva
NO Stram til vekselvis venstre og høyre
RO Strângeți alternativ la stânga și la dreapta
ET Pingutage vaheldumisi vasakule ja paremale
LT Priveržkite pakaitomis kairę ir dešinę
SE Dra fast växelvis vänster och höger
BG Затянете последователно наляво и надясно.
LV Priveržkite pakaitomis kairē ir dešīnē
FI Kiristä vuorotellen vasen ja oikea
GR Σφίχτε εναλλακτικά δεξιά και αριστερά
DK Dra fast växelvis vänster och höger

7

8

9

ALFA ROMEO GIULIETTA 10→
LANCIA YPSILON 06/11→
PEUGEOT 508 11→
SKODA RAPID 12→

10

EN For the guarantee to be valid/applicable, the adhesive must be attached under one of the roof bars
FR Pour que la garantie puisse s'appliquer, l'adhésif doit être impérativement collé sous l'une des barres
ES Para mantener la garantía, es necesario mantener el precinto derecho pegado bajo de una de las barras
DE Damit die Garantie gültig wird, muß das Klebeband zwingend unter einen des Dachträgers angebracht werden
IT La garanzia è valida solo se l'adesivo è stato applicato sotto una delle barre
NL Opgat de waarborg zou gelden is het imperatief van de zelfklever op één dragers te kleven
PT Para que a garantia possa ser aplicável, o adesivo de e ser colado por baixo de uma das barras
PL Aby zachować gwarancję, należy nakleić naklejkę pod jedną z belek
HU A garancia érvényességéhez, a matricát az egyik rúd aljára fel kell ragasztani
NO For at garantien skal gjelde, må etiketten festes på undersiden av en av takbøylene
RO Pentru ca garanția să poată fi aplicată, adezivul trebuie să fie imperativ lipit sub una din bare
ET Garantii kehtimiseks peab kleebis olema kinnitatud ühe katuseraami alla
LT Kad garantija galioti, lipdukas turi būti pritvirtintas po vienu iš stogo skersinių
SE För att garantin skall gälla måste etiketten fästas på undersidan av en av takbågarna
BG За да бъде валидна гаранцията / е приложимо, лепилото трябва да бъдат приложени по един от баровете на багажник.
LV Garantinin spēderli / ugun olabimesi iġin, yapışkan çatı raf çubuklardan birini altında eklenmelidir.
FI Takuu on voimassa vain, jos aetiketti kiinnitetään yhden kattokaareen alapuolelle
GR Για να έχει ισχύ η εγγύηση, το σημείο πρόσδεσης πρέπει να είναι βρισκείται οπωσδήποτε κάτω από μία από τις μπάρες της οροφής.
DK For at garantien skal være gældende, skal klæbemidlet være påført under en af tagbøjens tremmer

MONT BLANC France
35417 SAINT-MALO CEDEX
France
Type: BARRE DE TOIT / ROOF RACK
Modél : MB RoofBar AMC 5122
Max Load : 75 KG
Rxxxxxxx
OF: xxxxxx
245 122
A9-1