



**PHOENIX GOLD**

**ZB**  
series



**ZB8P**

8" Slim Active Bass Enclosure

User Manual

## PANEL CONTROLS AND FEATURES

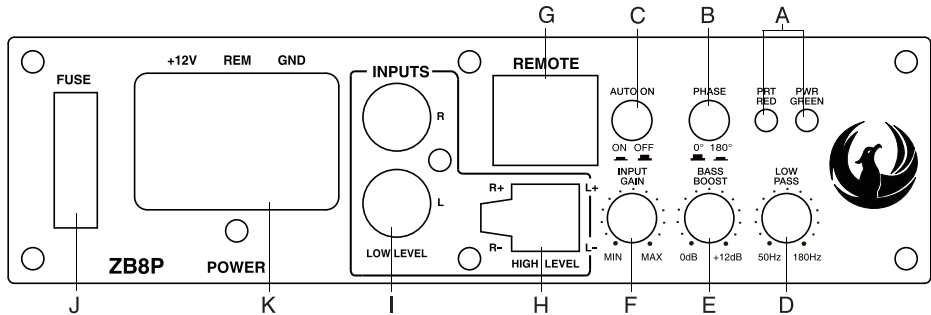

### A. POWER STATUS LED

This bi-coloured LED glows green when power is on and no problems are detected. If one of the protection circuits come on, the LED will glow RED.

### B. PHASE SHIFT

Use this switch to help compensate for time alignment problems in the system. Such problems usually result from having the subwoofer at a different distance from the listener than the other speakers in the system.

### C. AUTO POWER ON

The AUTO POWER ON (ON/OFF) is for high level (speaker level) connections. When the switch is in the "ON" position, the subwoofer will AUTO POWER ON when there is a signal input. If the amplifier detected no signal input, the amplifier will auto turn off. If you prefer to use the remote turn on/off connection, the switch is in the OFF position.

**(NOTE: Please connect the remote terminal to the remote output of head unit (See Fig 4) when you hear the unit turn ON/OFF POP noise from the subwoofer).**

### D. LOW PASS FILTER

This control allows you to define the frequency range you want the subwoofer amplifier to receive. The subwoofer will reproduce all sound below the frequency you set.

**Note: The low pass filter frequency can be higher or lower than the standard. There have +/-20% tolerance.**

### E. BASS BOOST

The BASS BOOST feature will increase the sound level in the bass frequencies.

### F. INPUT GAIN CONTROL

After you have installed your system, turn this control to minimum. Turn the head unit on (and the subwoofer will turn on via the remote connection). Turn the head unit volume to about 2/3 full level. Slowly turn up the subwoofer input gain control until you hear a small amount of distortion. Then reduce the level until the distortion is completely gone. Level the control at this setting.

### G. REMOTE LEVEL CONTROL PORT

Attach the included remote level control to control the volume level of the subwoofer independently.

### H. HIGH LEVEL (SPEAKER LEVEL) INPUTS

If your head unit does not have RCA outputs you can use the speaker outputs for the audio source for the subwoofer. Use the supplied cable and wire harness and connect the outputs properly as shown in the connection diagram in this manual.

### I. LOW LEVEL RCA INPUTS

Low level inputs are the recommended way to introduce the audio signal to the subwoofer if RCA outputs are present on your head unit or other signal source (such as a sound processor).

### J. FUSE

Do not use a fuse with a different value and never replace the fuse with a wire or coin.

### K. POWER INPUT TERMINAL

## WIRING

### LOW LEVEL INPUT WIRING

Low-level (RCA) input wiring is preferred for best audio performance. Most trunk and under-seat installations will require a 6-12 feet RCA cable. Always use a high quality cable.

**NOTE: Do not connect BOTH the high level and low level inputs from your receiver to your amplifier at the same time!**

**FIG 1**

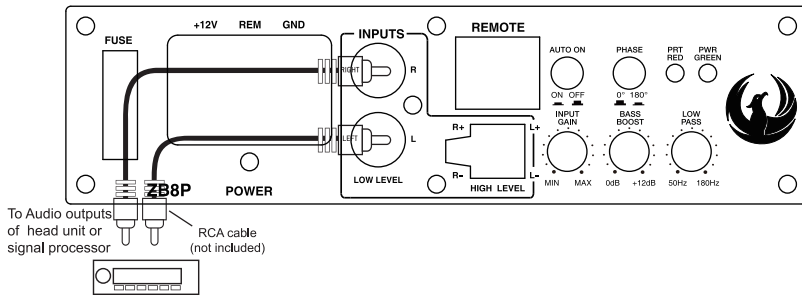

### HIGH LEVEL INPUT WIRING

The high level input(s) should only be used when your receiver lacks RCA outputs. If the RCA outputs are not present, connect the speaker outputs from the receiver to the high level input connector of the amplifier. Be sure to observe polarity to avoid audio phase problems.

**NOTE: Do not connect BOTH the high level and low level inputs from your receiver to your amplifier at the same time!**

**FIG 2**

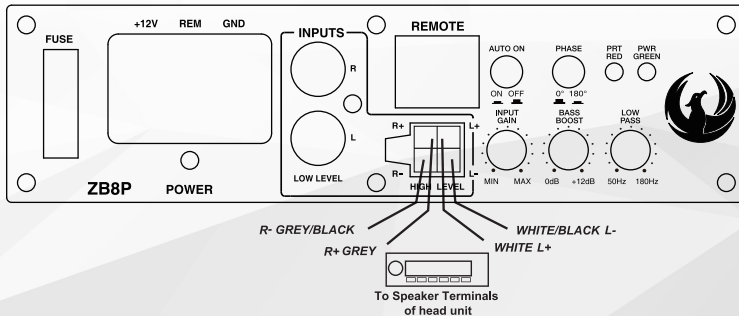

### POWER CONNECTIONS

Connect the ground terminal to the closest point on the chassis of the vehicle. Use 8 gauge (or heavier) wire to connect the ground cable.

Connect the remote terminal to the remote output of head unit using 16 gauge (or heavier) wire.

Connect an empty fuse holder within 16" (40 cm) of the car battery, and run 8 gauge (or heavier) cable from this fuse to the amplifier location. Then connect the fuse holder to the "BATT+" (+12V) connection on the subwoofer rear panel.

### WIRING

FIG 3

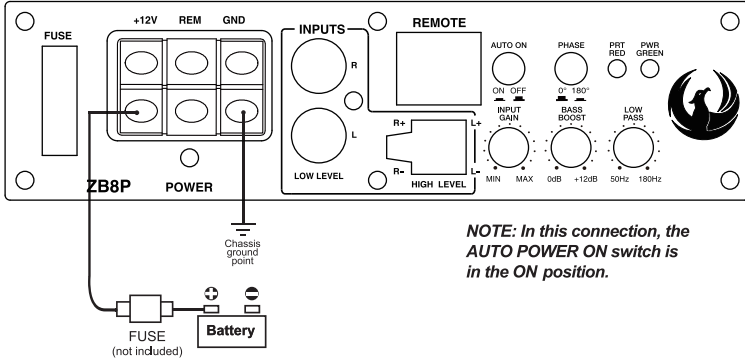

FIG 4

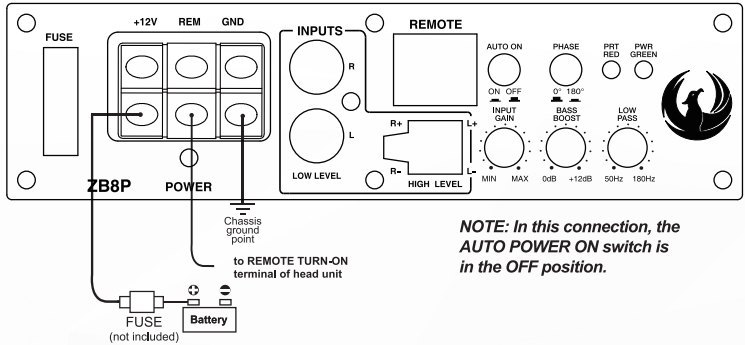
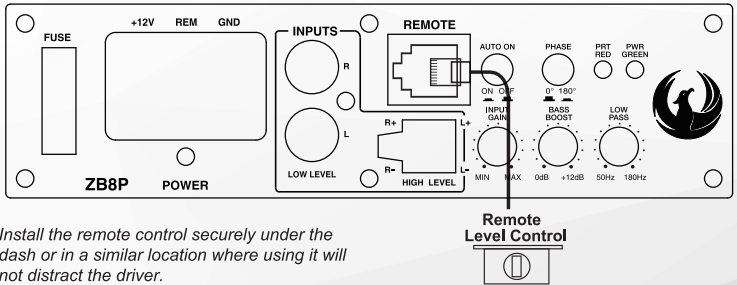

FIG 5



**SPECIFICATION**

<b>Class:</b>	A/B
<b>Frequency Response:</b>	20Hz – 180Hz
<b>Power Rating (MAX):</b>	600W
<b>Power Rating (RMS):</b>	300W
<b>SNR (1W @ 100Hz):</b>	>90dB
<b>Total Harmonic Distortion (THD):</b>	<0.5%
<b>Low Pass Filter (LPF):</b>	50Hz – 180Hz (12dB/Oct)
<b>Subsonic (Fixed From Factory):</b>	20Hz (12dB/Oct)
<b>Bass Boost @ 45Hz:</b>	0 – +12dB
<b>Input Sensitivity High-Level:</b>	0.58V – 7.8V
<b>Input Sensitivity Low-Level:</b>	0.15V – 4.65V
<b>Remote:</b>	Yes (Included)
<b>High-level Input:</b>	Yes
<b>Auto Turn-on:</b>	Yes (On/Off)
<b>Operating Voltage:</b>	10.8V – 15.6V
<b>Fuse Rating:</b>	20A
<b>Power Terminal:</b>	10mm <sup>2</sup>
<b>Dimensions (LxWxH):</b>	260 x 195 x 58mm
<b>Weight:</b>	2.95 kg

All specifications subject to change without notice.

## TROUBLESHOOTING

SYMPTOM	POSSIBLE REMEDY
<b>Products will not power up</b>	<p>Check to make sure you have a good ground connection.</p> <p>Check that the Remote Input (Turn-on) has at least 5V DC.</p> <p>Check that there is battery power on the(+) terminal.</p> <p>Check that there is at least 12V.</p> <p>Check all fuse, replace if necessary.</p> <p>Make sure that the Protection LED is not illuminated. If it is lit shut off the amplifier briefly, and then repower it.</p>
<b>Protection LED comes on when amplifier is powered up</b>	<p>Turn down the volume control on the head unit to prevent overdriving.</p> <p>Check that there is good air circulation around the amp.</p>
<b>No output</b>	<p>Check that all fuses are OK.</p> <p>Check that unit is properly grounded,</p> <p>Check that the Remote Input (Turn-on) has at least 5V DC.</p> <p>Check that the RCA audio cables are plugged into the proper inputs.</p>
<b>Low output</b>	<p>Reset the Level Control.</p> <p>Check the Crossover Control settings.</p>
<b>High hiss in the sound.</b>	<p>Disconnect all RCA inputs to the power sub's control panel. If the hiss disappears, then plug in the component driving the amplifier and unplug its inputs. If the hiss disappears at this point, go on until the faulty/ noisy component is found.</p> <p>It is best to set the amplifie's input level control as low as possible. The best subjective signal-to-noise ratio is achieved in this manner. Try to set the head unit as high as possible (without distortion).</p>
<b>Squealing noise is present.</b>	<p>Check for improperly grounded RCA interconnects.</p>
<b>Distorted sound.</b>	<p>Check that the Input Level Control is set to match the signal level of the head unit.</p>
<b>Engine noise (static type)</b>	<p>This is usually caused by poor quality RCA cables, which can pick up radiated noise. Use only the best quality cables, and route them away from power cables.</p>
<b>Engine noise (alternator whine)</b>	<p>Check that the RCA grounds are not shorted to the vehicle chassis.</p> <p>Check that the head unit is properly grounded.</p>





## ZB8P - 8" SLIM ACTIVE BASS ENCLOSURE

### INSTALLATION

To ensure proper installation, check that the speakers fit into your desired location - this could require removal of existing vehicle speakers. Check the surrounding area before drilling or cutting holes. DO NOT work near fuel tanks, fuel lines hydraulic lines or electrical wiring. Once installed make sure the speaker is firmly fixed in your vehicle.

Always ensure that the speaker and cables are securely attached and installed in such a way that no cables can be pinched or damaged. Phoenix Gold accepts no responsibility for damage or injury in relation to inappropriate installation of this product.

#### Disclaimer

Ensure your safety and the well-being of those around you by following these essential guidelines:

- Keep all product materials and packaging away from children, pets, or anyone at risk of suffocation.
- Exposure to noise levels above 85 dB can cause permanent hearing damage.
- Extreme sound frequencies reduce perception abilities that are essential in road traffic conditions; do not let loud volumes distract from being mindful behind the wheel.
- Phoenix Gold takes no responsibility for any physical harm or damage caused by improper use of their products.
- Ensure that all metals and raw materials are disposed of in accordance with local regulations and environmental standards to minimise any negative impact on the environment.

#### Warranty

Phoenix Gold products come with a limited warranty and are covered by our regional distribution partners and their terms and conditions. You can find out more information by contacting your local retailer or distributor.