

HAMRON



SV HUND-/LASTGALLER

BRUKSANVISNING

Viktigt! Läs bruksanvisningen före användning.
Spara den för framtida bruk.
(Original bruksanvisning).

NO HUNDE-/LASTEGITTER

BRUKSANVISNING

Viktig! Les bruksanvisningen nøye før bruk.
Ta vare på den for fremtidig bruk.
(Oversettelse av original bruksanvisning).

PL PRZEGRODA BAGAŻNIKA

INSTRUKCJA OBSŁUGI

Ważne! Przed użyciem uważnie przeczytaj instrukcję obsługi! Zachowaj ją na przyszłość.
(Tłumaczenie oryginalnej instrukcji).

EN PET/CARGO BARRIER

OPERATING INSTRUCTIONS

Important! Read the user instructions carefully before use. Save them for future reference.
(Translation of the original instructions).

DE HUNDE-/GEPÄCKGITTER

BEDIENUNGSANLEITUNG

Wichtig! Die Bedienungsanleitung vor der Verwendung bitte sorgfältig durchlesen! Für die zukünftige Verwendung aufbewahren.
(Bedienungsanleitung im Original).

FI KOIRA-/KUORMARITILÄ

KÄYTTÖOHJE

Tärkeää! Lue käyttöohje huolella ennen käyttöä!
Säilytä se myöhempiä käyttöä varten.
(Käännös alkuperäisestä käyttöohjeesta).

FR GRILLE POUR CHIENS/CARGAISON

MODE D'EMPLOI

Important! Lisez attentivement le mode d'emploi avant la mise en service. Conservez-le.
(Traduction des instructions originales).

NL HONDEN-/KOFFERBAKROOSTER

GEBRUIKSAANWIJZING

Belangrijk! Lees de gebruiksaanwijzing aandachtig door voordat u het apparaat gebruikt. Bewaar de gebruiksaanwijzing voor toekomstig gebruik.
(Vertaling van de originele instructies).

Rätten till ändringar förbehålles.
För senaste version av bruksanvisningen se www.jula.com

Med forbehold om endringer.
Nyeste versjon av bruksanvisningen finner du på www.jula.com

Z zastrzeżeniem prawa do zmian.
Najnowsza wersja instrukcji obsługi znajduje się na www.jula.com

Jula reserves the right to make changes.
For latest version of operating instructions, see www.jula.com

Änderungen vorbehalten.
Die aktuellste Version der Bedienungsanleitung finden Sie auf www.jula.com

Pidätämme oikeuden muutoksiin.
Katso käyttöohjeiden uusin versio täältä: www.jula.com

Nous nous réservons le droit d'apporter des modifications.
Pour la dernière version du manuel utilisateur, voir www.jula.com







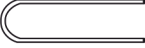

Wijzigingen voorbehouden.
Voor de nieuwste versie van de gebruiksaanwijzing, zie www.jula.com

Läs bruksanvisningen noggrant innan användning!

Spara den för framtida behov.

MONTERING**OBS!** Kontrollera regelbundet låsklämmorna på de vertikala rören och justera inställningen vid behov.

- Bredd: 90–145 cm
- Höjd 60–110 cm

Del	Benämning	Bild	Antal
A	Rakt rör		4
B	U-rör		4
C	Låsklämma		8
D	Plasthätta		8
E	Stötta		2
F	Ändstopp		4
G	Skruv		8
H	Låsvred		2
I	Gängskruv		2

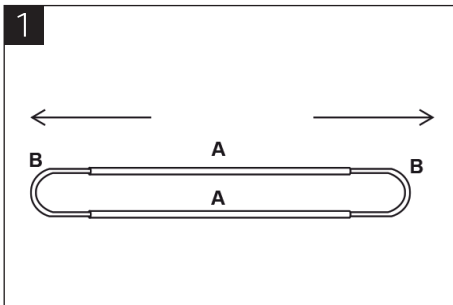

Dra ut U-röret (B) ur de raka rören (A).

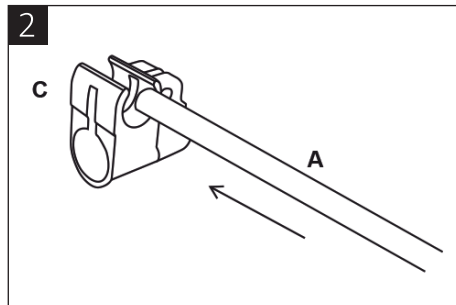

Trä på två låsklämmor (C) till varje rakt rör (A).
Justera låsstyckenas placering.

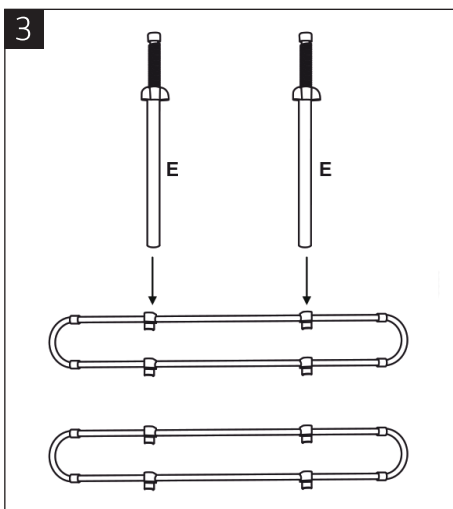

För stöttorna (E) genom låsklämmorna (C).

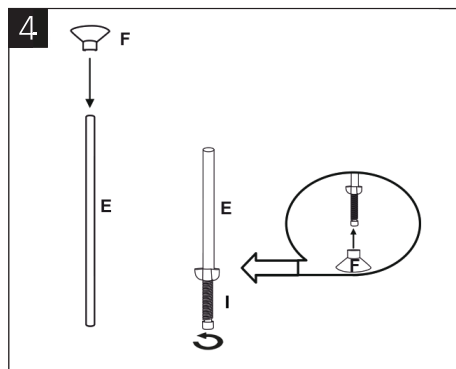

Skruva fast gängskruvarna (I) i stöttornas (E) ena ände. Montera passande ändstopp (F) på stöttorna (E).

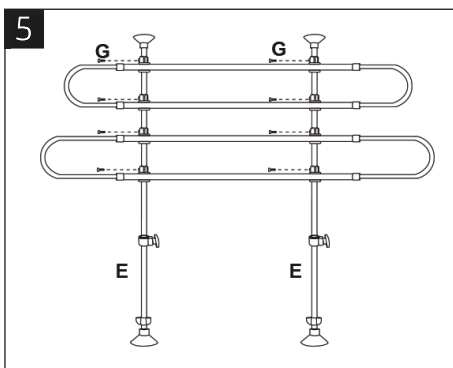

Justera tvärstyckenas höjd. Fixera låsklämmorna (C) med skruvarna (G).

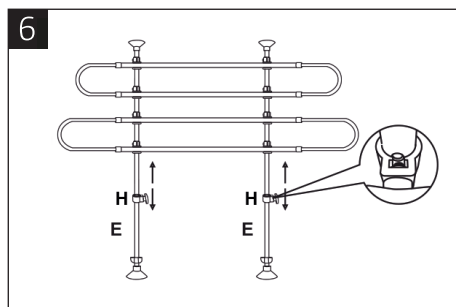

Justera stöttorna efter bilens höjd och dra åt låsvreden (H) för hand.

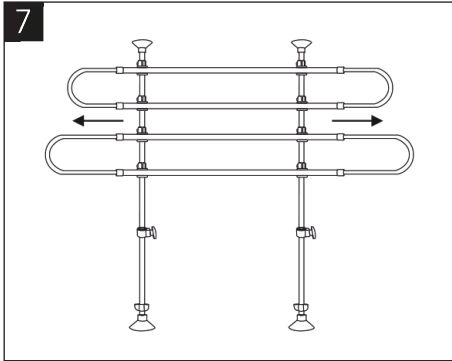

Justera tvärsyckena horisontellt.

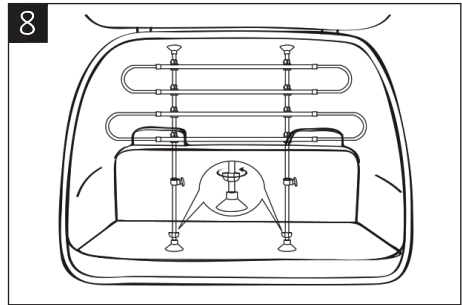

Placera hund-/lastgallret i bilen och dra åt vingmuttrarna moturs. Därmed är hund-/lastgallret klart för användning.









Les bruksanvisningen nøye før bruk!

Ta vare på den for fremtidig bruk.

MONTERING

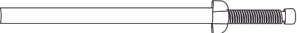
OBS! Kontroller regelmessig låseklemmene på de vertikale rørene og juster innstillingen ved behov.

- Bredde: 90–145 cm
- Høyde 60–110 mm

Del	Betegnelse	Bilde	Antall
A	Rett rør		4
B	U-rør		4
C	Låseklemme		8
D	Plasthette		8
E	Støtte		2
F	Endestopper		4
G	Skrue		8
H	Låseknott		2
I	Gjengeskruer		2

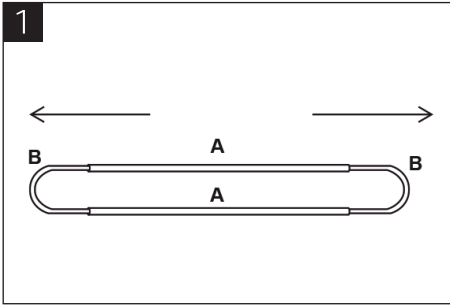

Dra ut U-røret (B) fra de rette rørene (A).

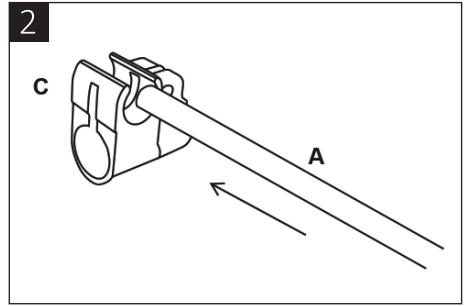

Tre to låseklammer (C) på hvert rette rør (A).
Juster låsestykkenes plassering.

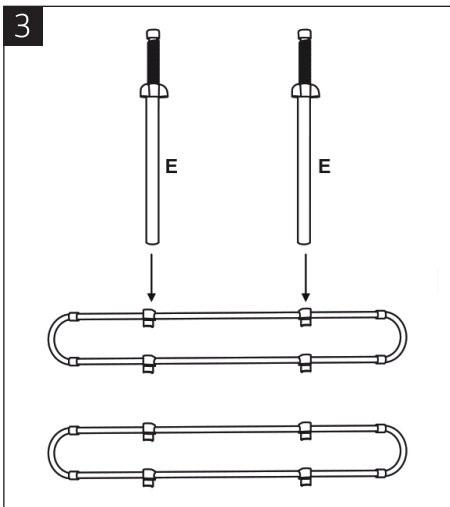

Før støttene (E) gjennom låseklammene (C).

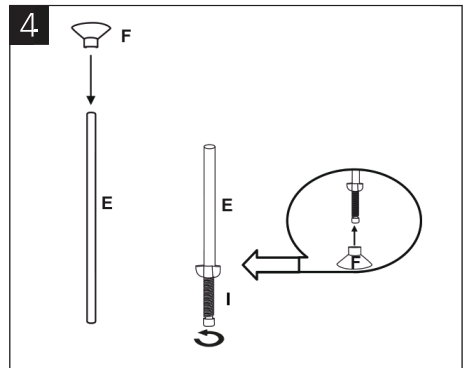

Skrue fast gjengeskruene (I) i støttene (E) ene ende.
Monter passende endestopper (F) på støttene (E).

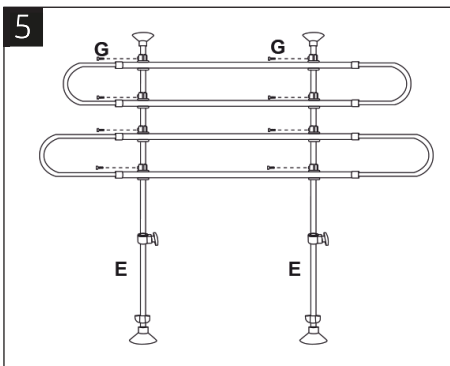

Juster tverrstykkenes høyde. Fest låseklammene (C) med skruene (G).

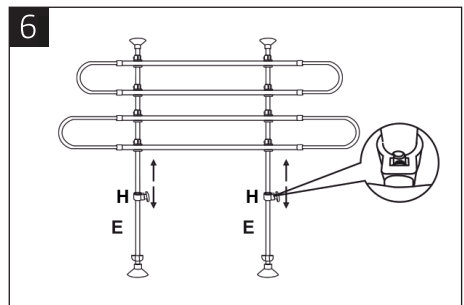

Tilpass støttene etter bilens høyde og stram låseknotten (H) for hånd.

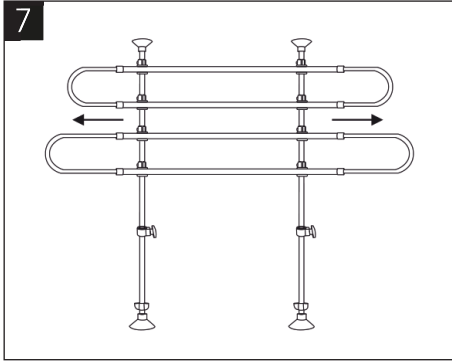

Juster tverrstykkene horisontalt.

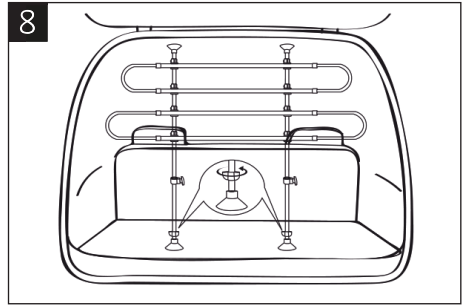

Plasser hunde-/lastegitteret i bilen og stram til vingemutterne moturs. Hunde-/lastegitteret er dermed klart til bruk.









Przed użyciem uważnie przeczytaj instrukcję obsługi!

Zachowaj ją na przyszłość.

MONTAŻ

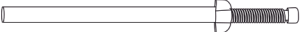
UWAGA! Regularnie sprawdzaj zaciski zabezpieczające na rurkach pionowych i dokonuj regulacji w razie potrzeby.

- Szerokość: 90–145 cm
- Wysokość 60–110 cm

Część	Nazwa	Rysunek	Liczba
A	Rurka prosta		4
B	Rurka w kształcie litery U		4
C	Zacisk zabezpieczający		8
D	Plastikowa nasadka		8
E	Podpora		2
F	Zatyczka		4
G	Wkręt		8
H	Pokrętło blokujące		2
I	Wkręt z łbem walcowym		2

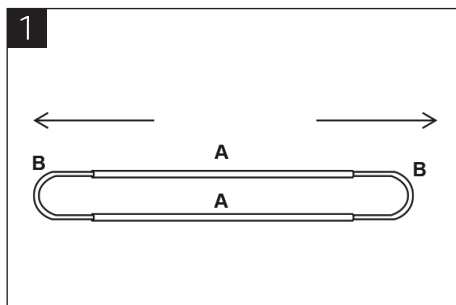

Wsuń rurkę w kształcie litery U (B) z rurek prostych (A).

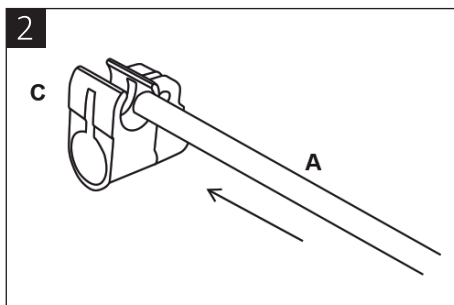

Na każdą rurkę prostą (A) nałóż dwa zaciski zabezpieczające (C).
Wyreguluj rozmieszczenie blokad.

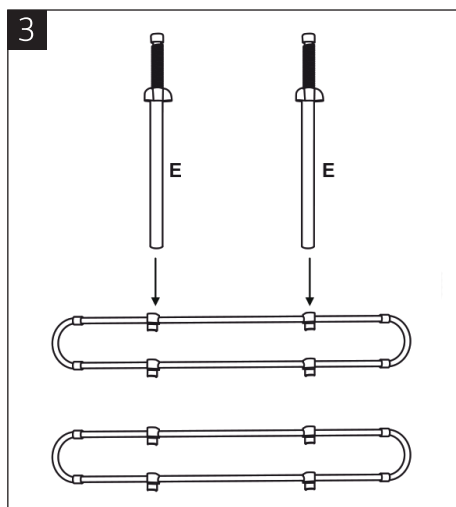

Wsuń podpory (E) przez zaciski zabezpieczające (C).

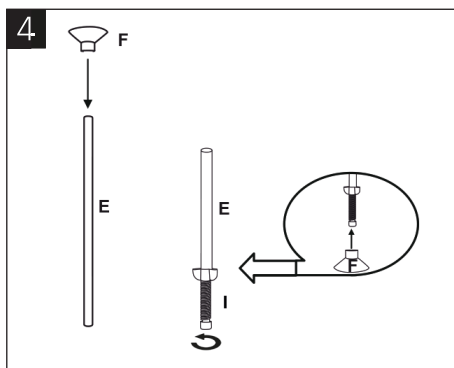

Przykręć wkrety z łbem walcowym (I) na jednym końcu każdej z podpór (E). Zamocuj odpowiednie zatyczki (F) na podporach (E).

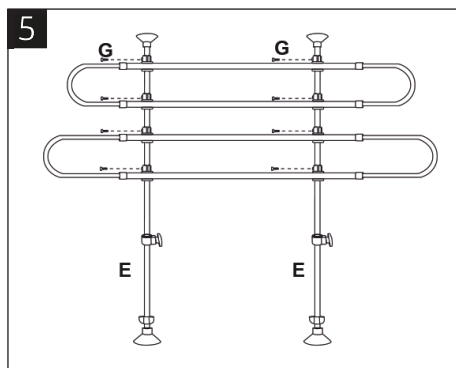

Wyreguluj wysokość poprzeczek. Zablokuj zaciski zabezpieczające (C) wkretami (G).

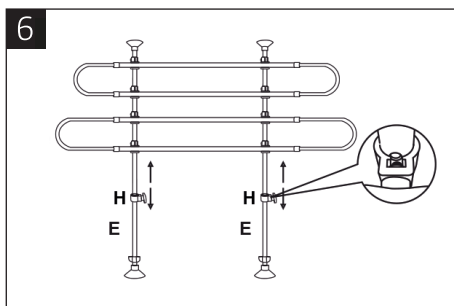

Dopasuj podpory do wysokości samochodu i ręcznie dokręć pokrętła blokujące (H).

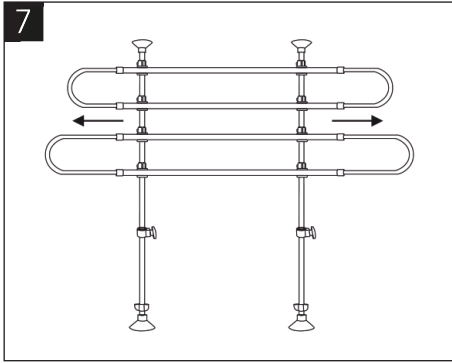

Wyreguluj poprzeczki w poziomie.

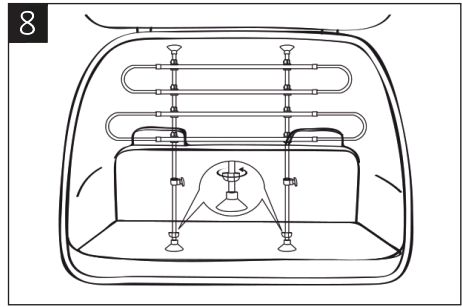

Zamontuj przegrodę bagażnika w samochodzie i dokręć nakrętki motylkowe w lewo. Przegroda jest już gotowa do użycia.







Read the User Instructions carefully before use!

Save these instructions for future reference.

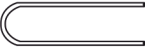
ASSEMBLY

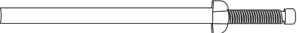
NOTE: Regularly check the locking clamps on the vertical tubes and adjust if necessary.

- Width: 90–145 cm
- Height 60–110 cm

Part	Designation	Diagram	Quantity
A	Straight tube		4
B	U-tube		4
C	Locking clamp		8
D	Plastic cap		8
E	Stay		2
F	End stop		4
G	Screw		8
H	Locking handle		2
I	Headless screw		2

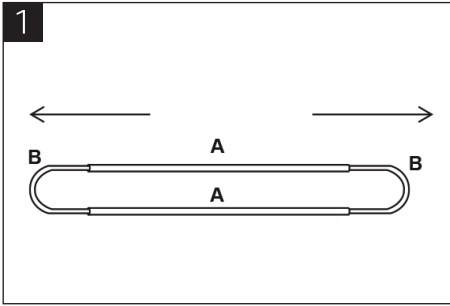

Pull out the U-tube (B) from the straight tubes (A).

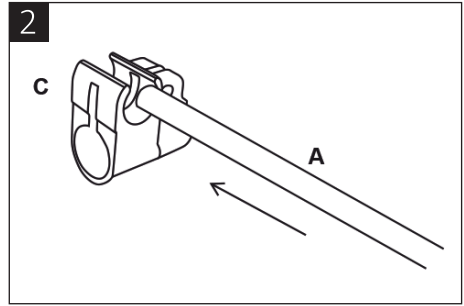

Fit two locking clamps (C) on each straight tube (A).
Adjust the position of the locking clamps.

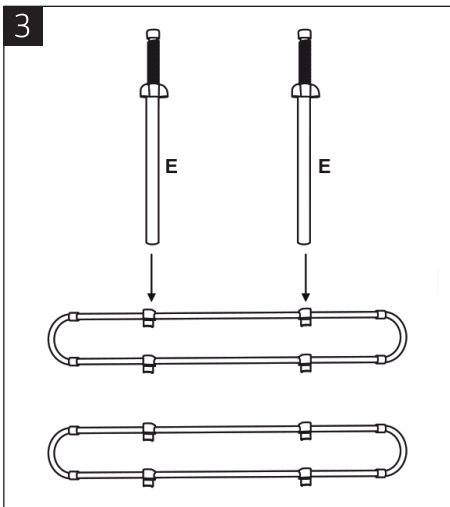

Insert the stays (E) through the locking clamps (C).

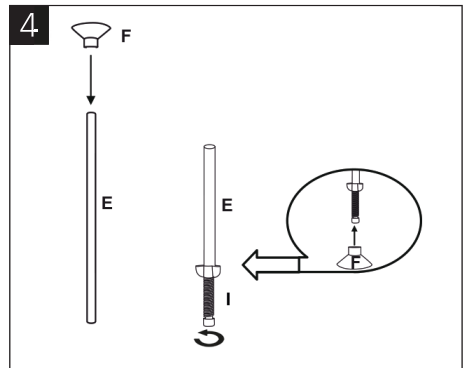

Screw the headless screws (I) in one end of the stays (E). Attach an appropriate end stop (F) on the stays (E).

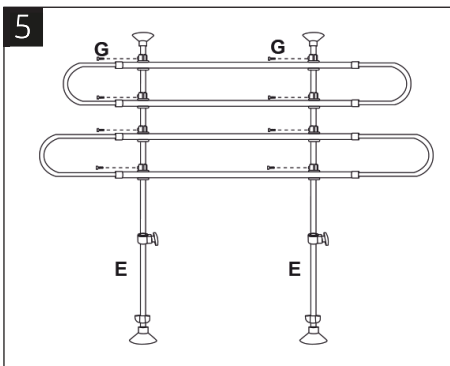

Adjust the height of the cross-sections.
Secure the locking clamps (C) with screws (G).

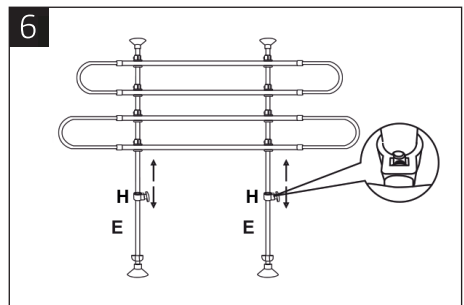

Adjust the stays to the height of the car and
tighten the locking handle (H) by hand.

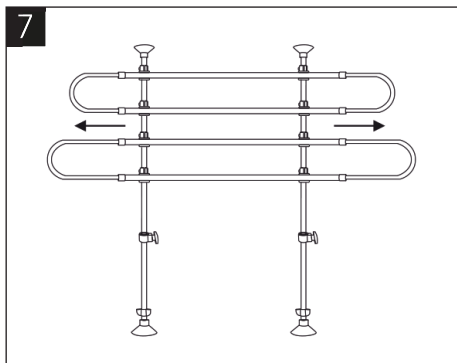

Adjust the cross-sections horizontally.

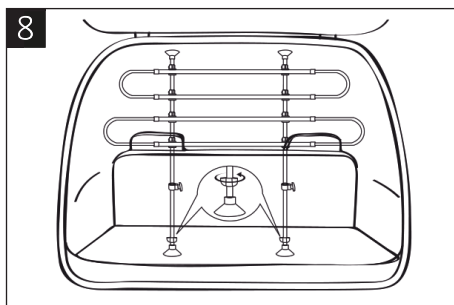









Position the pet/cargo barrier in the car and tighten the wing nuts anticlockwise. The pet/cargo barrier is now ready to use.

Die Bedienungsanleitung vor der Verwendung bitte sorgfältig durchlesen!

Für späteres Nachschlagen aufbewahren.

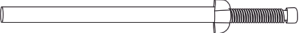
MONTAGE**HINWEIS: Kontrollieren Sie regelmäßig die Klemmverbinder an den vertikalen Röhren und passen Sie die Einstellungen gegebenenfalls an.**

- Breite: 90–145 cm
- Höhe 60–110 cm

Teil	Bezeichnung	Abbildung	Anzahl
A	Gerades Rohr		4
B	U-Rohr		4
C	Klemmverbinder		8
D	Kunststoffkappe		8
E	Strebe		2
F	Endanschlag		4
G	Schraube		8
H	Sperrknopf		2
I	Gewindeschraube		2

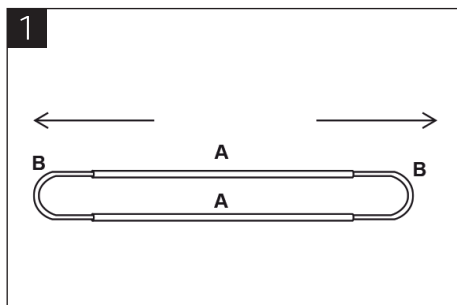

Ziehen Sie das U-Rohr (B) aus den geraden Rohren (A).

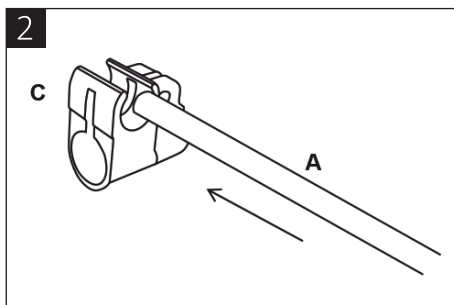

Stecken Sie zwei Klemmverbinder (C) auf jedes gerade Rohr (A).

Passen Sie die Klemmverbinder-Position an.

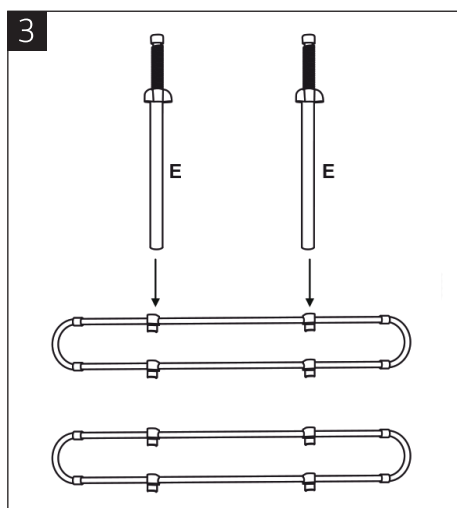

Stecken Sie die Streben (E) durch die Klemmverbinder (C).

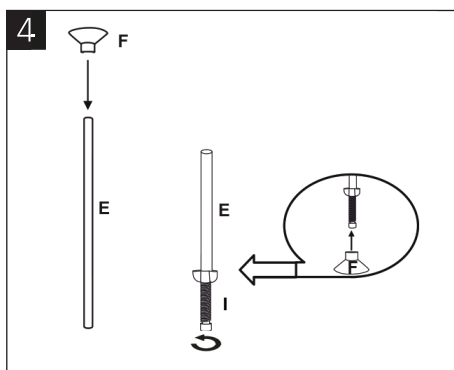

Schrauben Sie die Gewindeschrauben (I) an ein Ende der Streben (E). Montieren Sie den passenden Endanschlag (F) an die Streben (E).

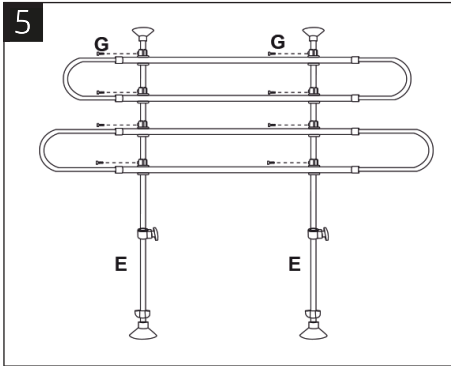

Passen Sie die Höhe der Querstreben an.
Fixieren Sie die Klemmverbinder (C) mit den
Schrauben (G).

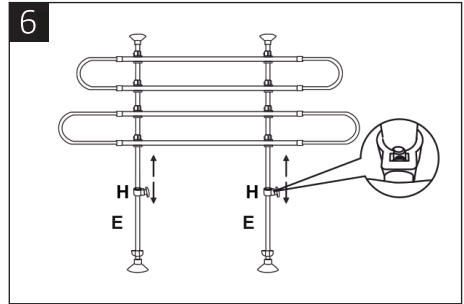

Stellen Sie die Streben auf die Fahrzeughöhe ein
und ziehen Sie den Sperrknopf (H) von Hand fest.

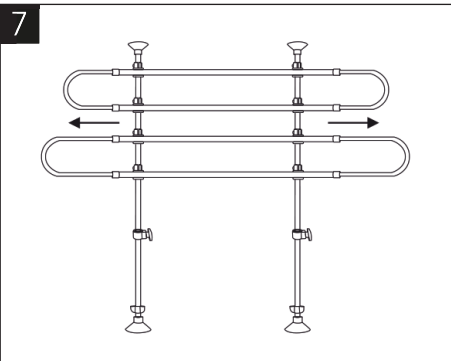

Passen Sie die Querstreben horizontal an.

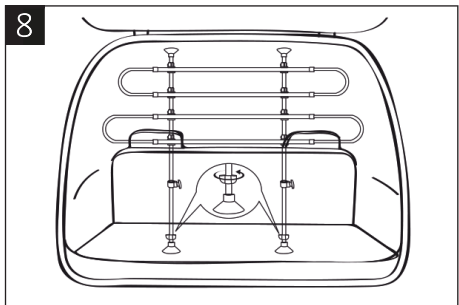

Hunde-/Gepäckgitter im Auto platzieren und
die Flügelmuttern gegen den Uhrzeigersinn
festziehen. Das Hunde-/Gepäckgitter ist jetzt
einsatzbereit.







Lue käyttöohje huolella ennen käyttöä!

Säilytä se myöhempää käyttöä varten.

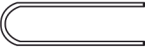
ASENNUS

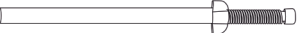
HUOM! Tarkista säännöllisesti pystyputkien lukituskiinnikkeet ja säädä tarvittaessa asetusta.

- Leveys: 90–145 cm
- Korkeus 60–110 cm

Osa	Nimike	Kuva	Määrä
A	Suora putki		4
B	U-putki		4
C	Lukituskiinnike		8
D	Muovihattu		8
E	Tuki		2
F	Päätyrajoitin		4
G	Ruuvi		8
H	Lukitusnuppi		2
I	Kierreruuvi		2

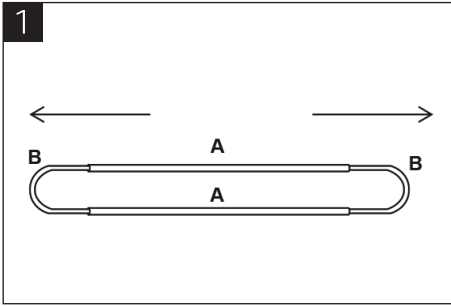

Vedä U-putki (B) ulos suorista putkista (A).

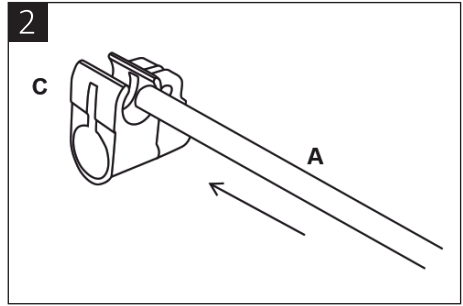

Kierrä kaksi lukituskiinnikettä (C) kuhunkin suoraan putkeen (A).
Sääda lukitusosien asentoa.

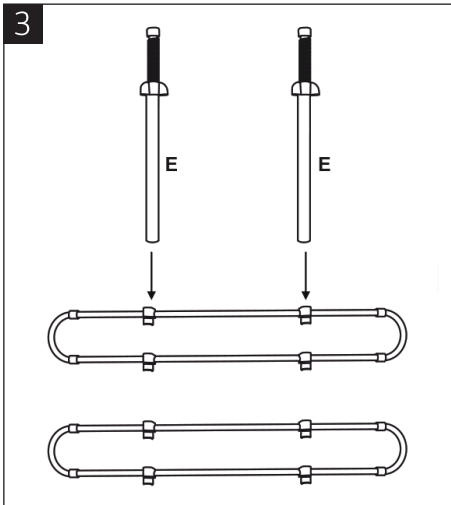

Vie tuet (E) lukituskiinnikkeiden (C) läpi.

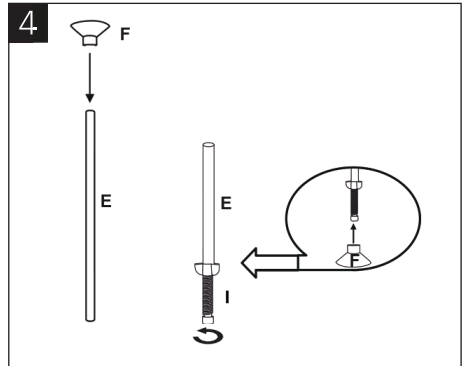

Ruuvaa ruuvit (I) tukien (E) toiseen päähän.
Asenna sopivat päätykappaleet (F) tukiin (E).

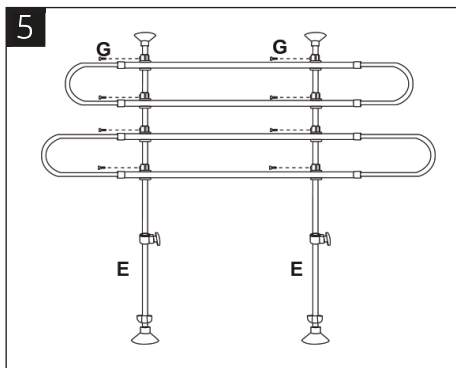

Sääda poikkipalkkien korkeus. Kiinnitä lukituskiinnikkeet (C) ruuveilla (G).

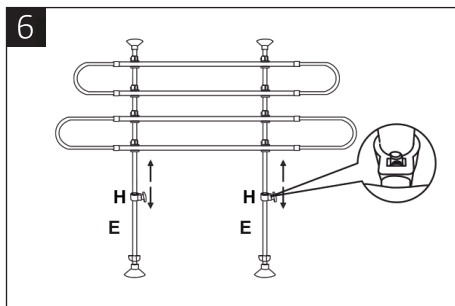

Sääda tuet auton korkeuden mukaan ja kiristä lukitusnupit (H) käsin.

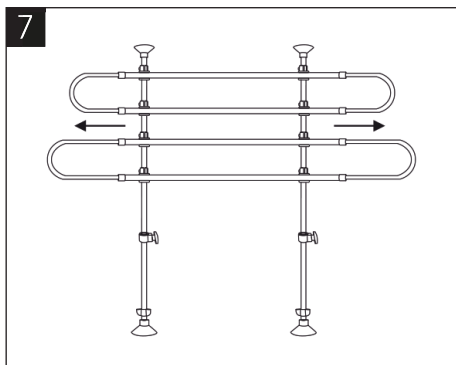

Sääda poikkipalkit vaakasuoraan.

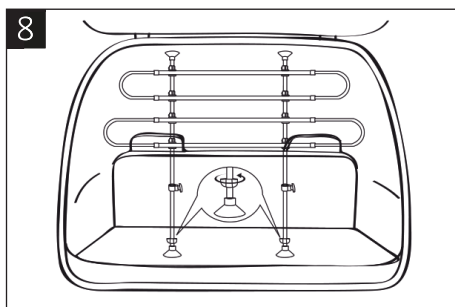

Aseta koira-/kuormaritiä autoon ja kiristä siipimutterit vastapäivään. Koira-/kuormaritiä on nyt käyttövalmis.









Lisez attentivement le mode d'emploi avant utilisation !

Conservez-le pour toute consultation ultérieure.

MONTAGE

REMARQUE ! Contrôlez régulièrement les pinces de verrouillage sur les tubes verticaux et ajustez l'installation si nécessaire.

- Largeur : 90 à 145 cm
- Hauteur 60–110 cm

Partie	Dénomination	Figure	Quantité
A	Tube droit		4
B	Tube en U		4
C	Pince de verrouillage		8
D	Garniture en plastique		8
E	Poteau		2
F	Butée		4
G	Vis		8
H	Bouton de verrouillage		2
I	Vis fileté		2

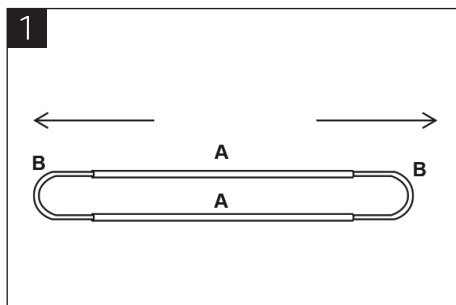

Retirez le tube en U (B) des tubes droits (A).

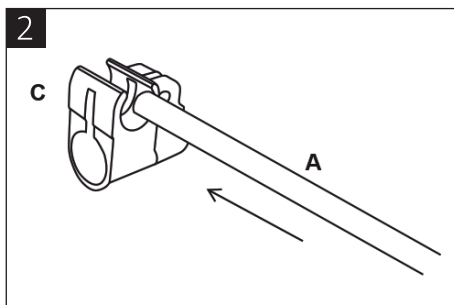

Engagez deux pinces de verrouillage (C) sur chaque tube droit (A).
Réglez la positions des verrous.

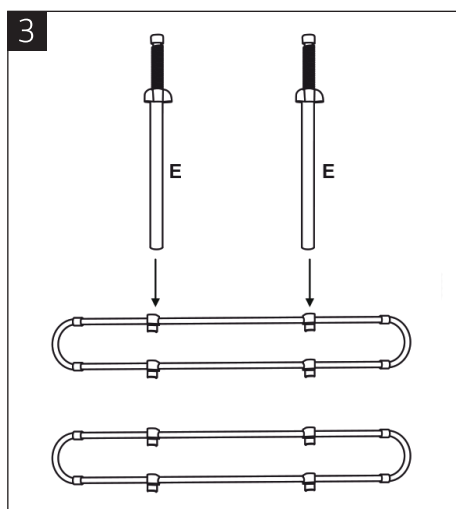

Passez les poteaux (E) dans les pinces de verrouillage (C).

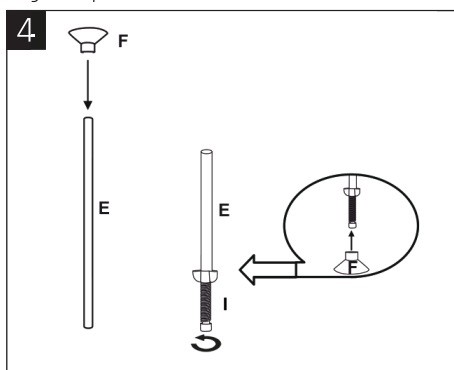

Serrez les vis filetées (I) à chaque extrémité des poteaux (E). Montez la butée correspondante (F) sur chaque poteau (E).

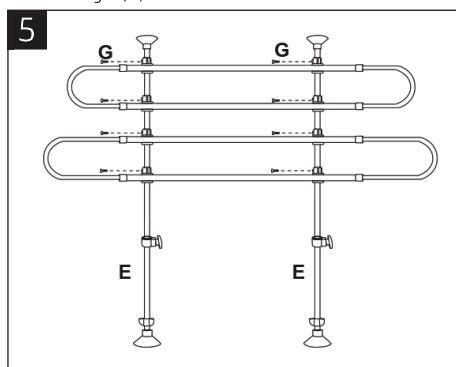

Réglez la hauteur des traverses. Fixez les pinces de verrouillage (C) avec les vis (G).

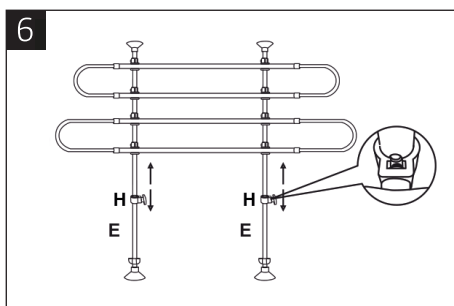

Réglez les poteaux en fonction de la hauteur de la voiture et serrez les boutons de verrouillage (H) à la main.

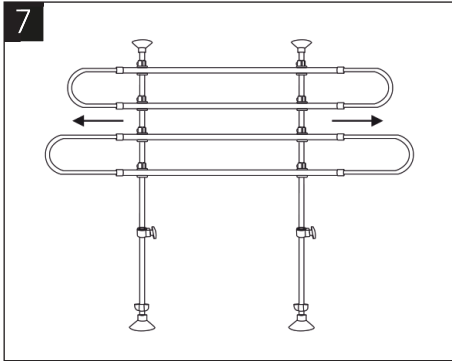

Réglez les traverses horizontalement.

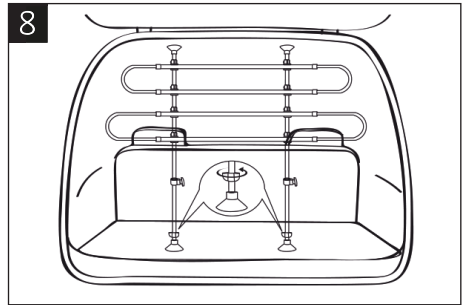

Placez la grille pour chiens/cargaison dans la voiture et serrez les vis à oreilles dans le sens horaire. La grille pour chiens/cargaison est maintenant prête à l'emploi.









Lees de gebruiksaanwijzing zorgvuldig vóór de ingebruikname.

Bewaar hem voor toekomstig gebruik.

MONTAGE

LET OP! Controleer regelmatig de borgklemmen op de verticale buizen en pas indien nodig de instelling aan.

- Breedte: 90–145 cm
- Hoogte 60–110 cm

Onderdeel	Benaming	Afbeelding	Aantal
A	Rechte buis		4
B	U-buis		4
C	Borgklem		8
D	Plastic dop		8
E	Steun		2
F	Eindstop		4
G	Schroef		8
H	Vergrendelknop		2
I	Schroefdraad		2

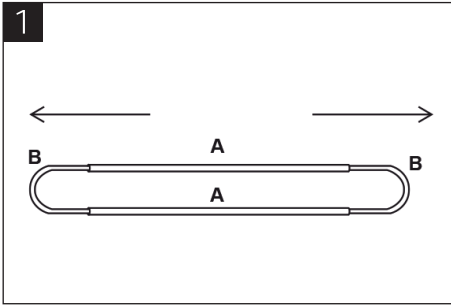

Trek de U-buis (B) uit de rechte buizen (A).

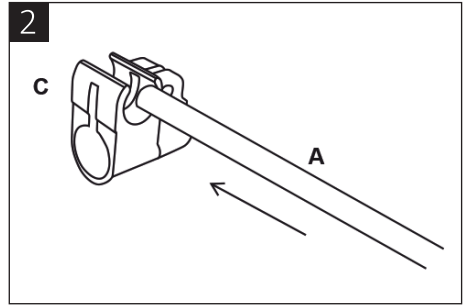

Zet twee borgklemmen (C) op elke rechte buis (A).

Pas de positie van de vergrendelingsstukken aan.

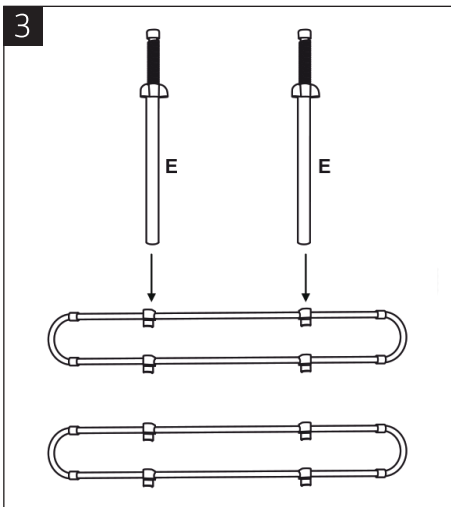

Steek de steunbuizen (E) door de borgklemmen (C).

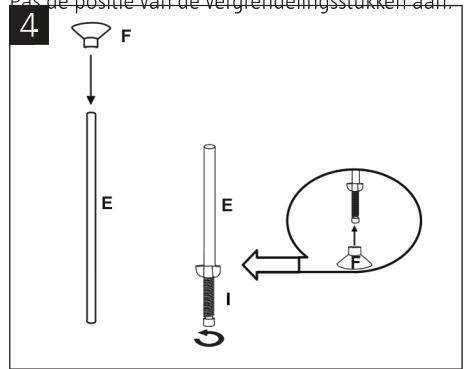

Draai de schroefdraad (I) vast in een uiteinde van de steunbuizen (E). Monteer de juiste eindstop (F) op de steunbuizen (E).

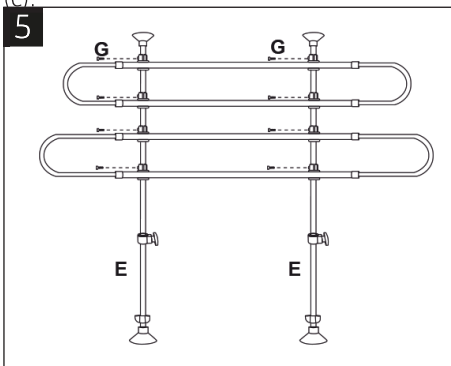

Pas de hoogte van de dwarsstukken aan. Zet de borgklemmen (C) vast met de schroeven (G).

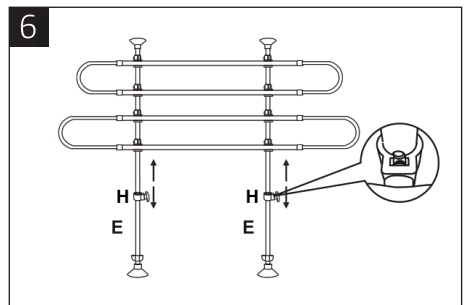

Pas de steunbuizen aan de hoogte van de auto aan en draai de vergrendelknoppen (H) met de hand aan.

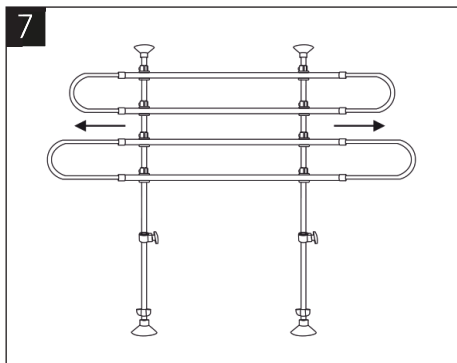

Pas de dwarsstukken horizontaal aan.

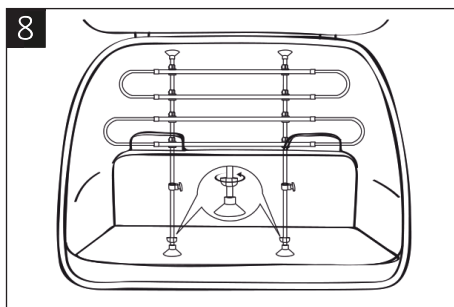

Plaats het honden-/kofferbakrooster in de auto en draai de vleugelmoeren tegen de klok in vast. Het honden-/kofferbakrooster is nu klaar voor gebruik.

